

ASCALE

INS
TA
LA
TI
ON Manual

*Guide for the precise installation
and positioning of our Ascale panels.*



INDEX

1	PRODUCT <i>PRODUCTO</i>	04
2	HANDLING AND STORAGE <i>MANIPULACIÓN Y ALMACENAJE</i>	12
3	RECEPTION AND CUALITY CONTROLS <i>RECEPCIÓN Y CONTROLES DE CALIDAD</i>	20
4	PRE- DESIGN RECOMMENDATIONS <i>RECOMENDACIONES PREVIAS DE DISEÑO</i>	24
5	CUTTING AND WORKING WITH THE MATERIAL <i>CORTES Y ELABORACIONES</i>	24
6	INSTALLATION <i>COLOCACIÓN</i>	28
7	GROUTING <i>REJUNTADO</i>	32
8	BONDING BRIDGES <i>PUENTES DE UNIÓN</i>	34
9	ADHESIVES <i>ADHESIVOS</i>	35

ADVANTAGES

Ascale is a leading brand in the large-format sintered slab market, where each product represents the fusion of expertise and the application of cutting-edge technological innovation. This unique combination enables Ascale to deliver products of exceptional quality and unmatched versatility, providing solutions that meet the most diverse design needs and demands.

Whether for architects, interior designers, builders, or those simply looking to transform their homes, Ascale's commitment to quality, innovation, and customer satisfaction ensures that each project becomes a masterpiece, where beauty merges with functionality to create spaces that inspire and captivate in equal measure.

Why choose Ascale?

Our sintered stone offers optimal technical performance for any surface, matching or even surpassing the aesthetic appeal of other materials.

Our collections are thoughtfully designed to meet the needs of every audience; our portfolio includes a wide range of marble, concrete, stone, wood, metal, and basic color options. Our mission is to create spaces that evoke feelings of comfort in every setting.



DIMENSION AND APPEARANCE

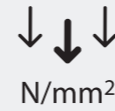

FLEXURAL STRENGTH



WATERPROOF



THERMAL RESISTANCE



RESISTANCE TO DEEP ABRASION



FROST RESISTANCE



RESISTANCE TO SUPERFICIAL ABRASION



CRAZING RESISTANCE



CHEMICAL RESISTANCE



SCRATCH RESISTANCE



STAIN RESISTANCE



FIREPROOF





CHROMATC RANGE

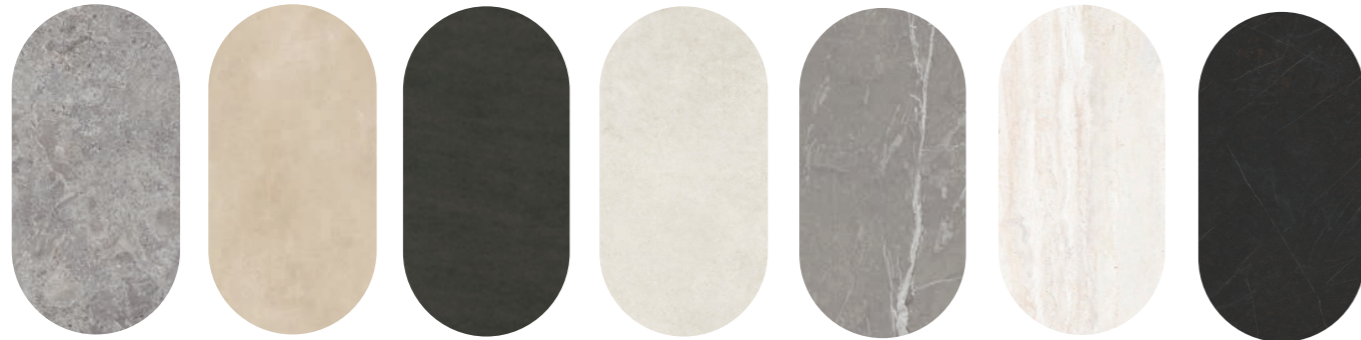

BORGOGNA SILVER ARIZONA SAND ETNA BLACK URBAN WHITE CARDOSO GRAY TIVOLI WHITE ALLURE BLACK



PALOMASTONE LINEN MOON BLACK COSMOPOLITA IVORY COSMOPOLITA SILVER COSMOPOLITA GRAY BOREAL UMBER BOREAL SAND

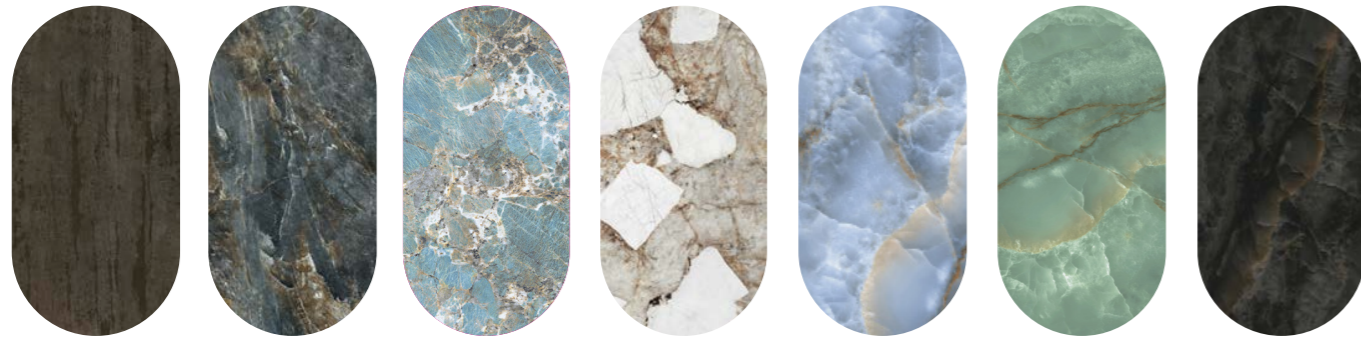

MILLENIUM COPPER LABRADORITE ROYALBLUE AMAZONITE SEAGREEN PATAGONIA GOLD ONICE BLUE ONICE SEAGREEN ONICE BLACK



ONICE LUX WHITE ANTALYA SAND CEPPO DI GRE DUNE GRAY PIERRE BLUE NEBULA BROWN LAURENT BLACK



CHROMATC RANGE



MONTBLANC WHITE ARMANI SILVER BELVEDERE BLACK MACCHIA-VECCHIA GOLD CROTONE PULPIS ARABESCATTO WHITE ALTO STATUARIO



MARQUINA BLACK GRASSI WHITE TAJ MAHAL ALMOND LUCCA GOLD TORANO STATUARIO VAGLI GOLD DUCAL GOLD



CRYSTAL LUX WHITE LASA WHITE ALPI WHITE GRUM BLACK

FINISHES

MATT / POLISHED / VELVET / FEEL



FORMAT

162 x 324 cm / 128" x 64" | ^(6 mm) 162 x 324 cm 128" x 64"



THICKNESS

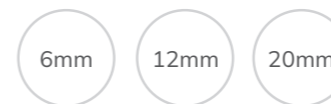

6mm
WALL TILE:
Interior and outdoor.
FAÇADES.
FLOORING:
Interior and outdoor
FURNITURE.

12mm
COUNTERTOPS:
Kitchen and bath.
FLOORING:
Outdoor.

20mm
COUNTERTOPS:
Kitchen and bath.
FLOORING:
Outdoor.



TECHNICAL FEATURES
CARACTERÍSTICAS TÉCNICAS

PROPIEDADES FÍSICO -QUÍMICAS PHYSICAL-CHEMICAL PROPERTIES	NORMA DE ENSAYO STANDARD TEST	VALOR REQUERIDO REQUIRED VALUE	VALOR MEDIO AVERAGE VALUE
Espesor Thickness	ISO 10545-3	Cumple/Complies	Cumple/Complies
Absorción de agua Water absorbtion	ISO 10545-3	≤ 0,5%	≤ 0,1%
Fuerza de rotura Breaking strenght	ISO 10545-4	≥ 700 N e<7,5 mm ≥ 1300 N e≥7,5 mm	≥ 1000 N e=6mm ≥ 3000 N e=8mm
Resistencia a la flexión Modulus of rupture	ISO 10545-4	R ≥ 35 N/mm2	≥ 50 N/mm2
Resistencia al impacto Impact resistance	ISO 10545-5	Valor declarado Declared value	>0,8 sin defectos visibles / no visible defects
Resistencia a la abrasión superficial Resistance to surface abrasion	ISO 10545-7	Valor declarado Declared value	Valor declarado Declared value
Dilatación térmica lineal Linear thermal expansion	ISO 10545-8	Valor declarado Declared value	5,7.10-6°C
Resistencia al choque térmico Thermal shock resistance	ISO 10545-9	Resistente Resistant	Resistente Resistant
Expansión por humedad Moisture expansion	ISO 10545-10	Valor declarado Declared value	<0,1 mm/m
Resistencia al cuarteo Crazing resistance	ISO 10545-11	Resistente Resistant	Resistente Resistant
Resistente a la helada Frost resistance	ISO 10545-12	Resistente Resistant	Resistente Resistant
Resistencia química: productos de limpieza Chemical resistance: Cleaning products	ISO-10545-13	B	A
Resistencia química: Aditivos piscinas Chemical resistance: Swimming pool salts	ISO-10545-13	B	A
Resistencia química: Ácidos de baja concentración Chemical resistance: Low concentration acids	ISO-10545-13	Valor declarado Declared value	LA acabado mate LB acabado pulido
Chemical resistance: Low concentration bases	ISO-10545-13	Valor declarado Declared value	LA acabado mate LB acabado pulido
Resistencia a las manchas Resistance to stains	ISO 10545-14	Min.3	Min. 5 acabado mate Min. 4 acabado pulido
Emisión de plomo y cadmio Determination of lead and cadmium	ISO 10545-15	Valor declarado Declared value	Cadmium < 0,01 mg/l Lead < 0,1 mg/l
Resistencia al calor seco Dry heat resistance	EN 13310	Declared value	Resistente Resistant
Resistencia UV UV Resistance	DIN 51094	Declared value	Sin cambios No change

Technical information	U.M.	6 mm	12 mm	20 mm
Slab surface m2	5.12	5.12	5.12	
Slab weight kg	76 149 253			
Weight per m2 kg	15 29 49			
Slabs per trestle* nr.	44 22 12			
Net m2 per trestle m2	225.28 112.64 61.44			
Metal trestle weight kg	210		210	
Full trestle weight kg	3589 3377 3221			
Dimensions of trestle including packaging	mm	3300x750x1900		

2.1 SLAB HANDLING

Transport with clamps

It's the best way to move 12 and 20 mm thick Ascale slabs. Always pay attention to the movement and handling of the slabs to prevent splintering or breakage. Ascale recommends using the following type of clamp for lifting and moving individual slabs:

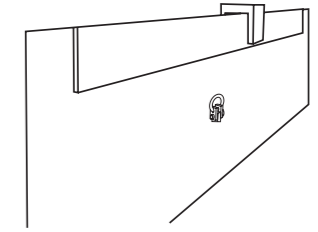
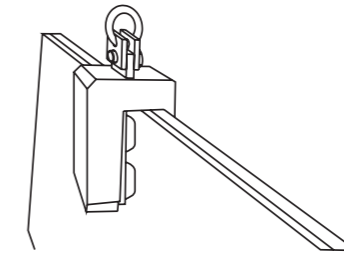
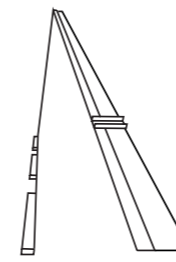
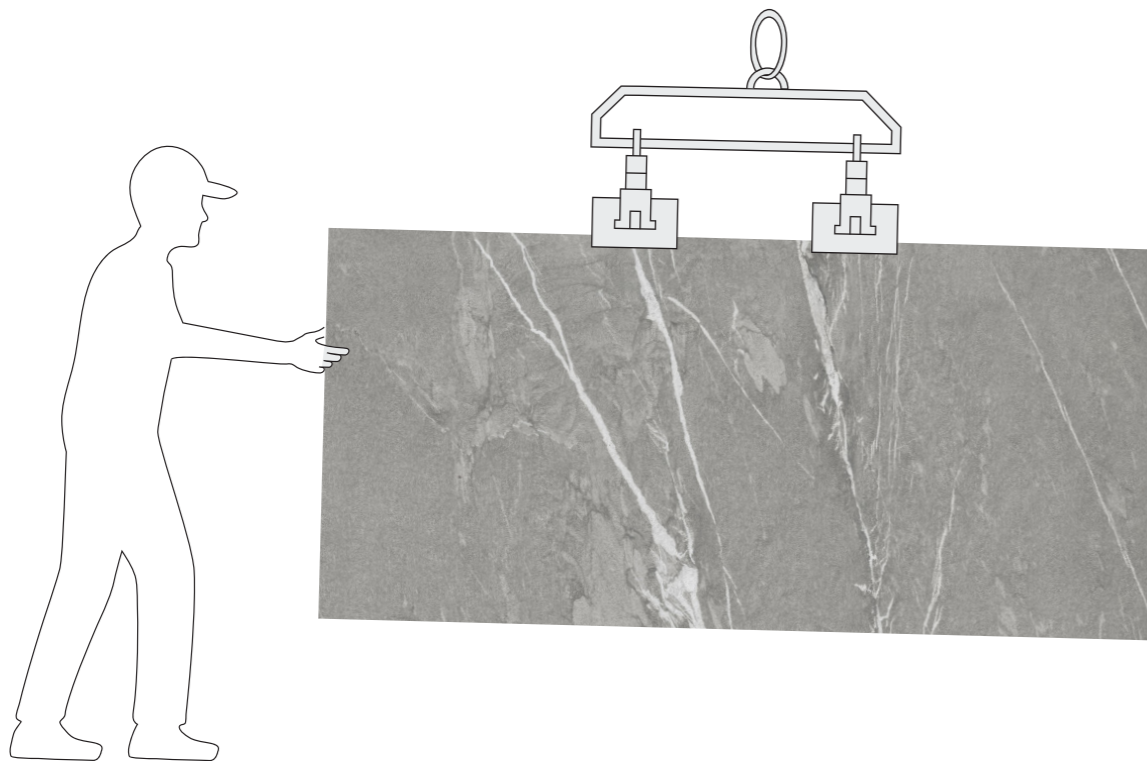

The additional width of this clamp will prevent the slab from bending during handling to, thus, prevent undesirable breakage. Recommendations:

- Clamping more than 2 slabs at the same time is not recommended.
- Make sure to cover all metal surfaces that may come into contact with the slab with adhesive foam tape.

If this type of clamp is not available, use a 2 cm thick plank of approximately 3 m x 20 cm so the clamp can catch 12 mm slabs.

Fixing the ends of the slab with jacks to the plank so the slab doesn't sag during handling is recommended.

Position the plank to the rear of the slab to be lifted.

- 1) Place the clamp on the slab and plank.
- 2) Fix the clamp and lift the slab and plank with care.
- 3) Avoid sudden changes in direction.

Transport with slings

An adequate system for moving several slabs at the same time. Using canvas slings is recommended.

Metal slings must not be used to handle Ascale slabs. Using wooden spacers is recommended to prevent direct contact between the slings and slabs

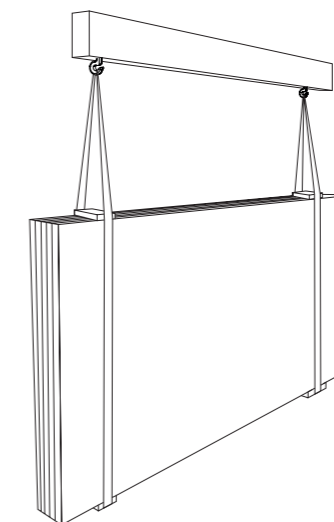
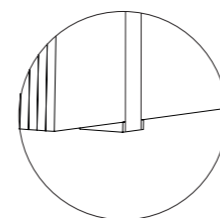
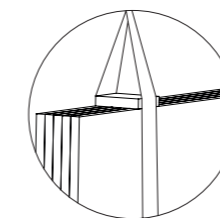

2.2 MANUAL TRANSPORT

Always keep in mind the weight of anything that needs to be transported. Get help from any type of support and never move slabs in a flat horizontal position as this may cause excessive buckling.

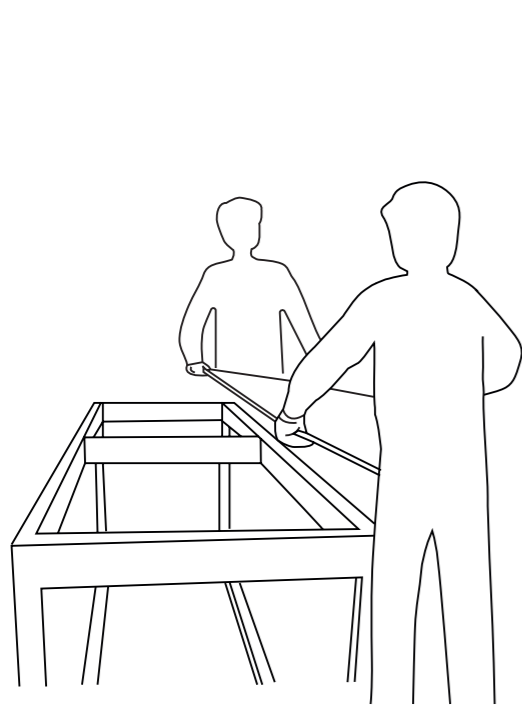

✘ INCORRECT

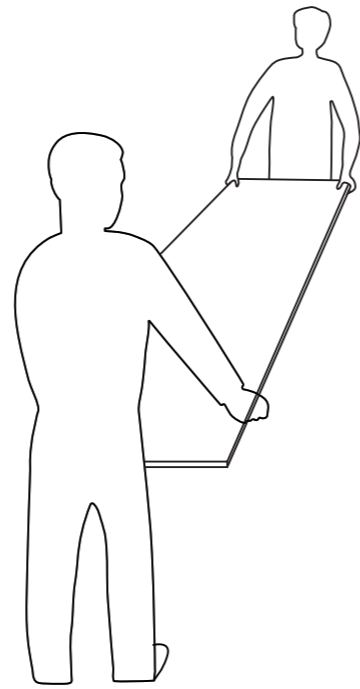

✘ INCORRECT

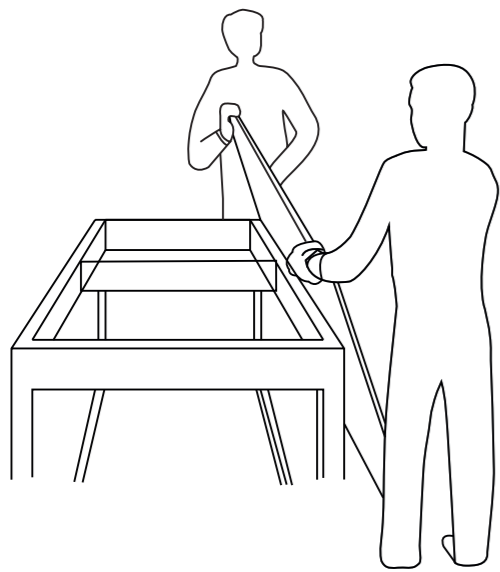

✔ CORRECT

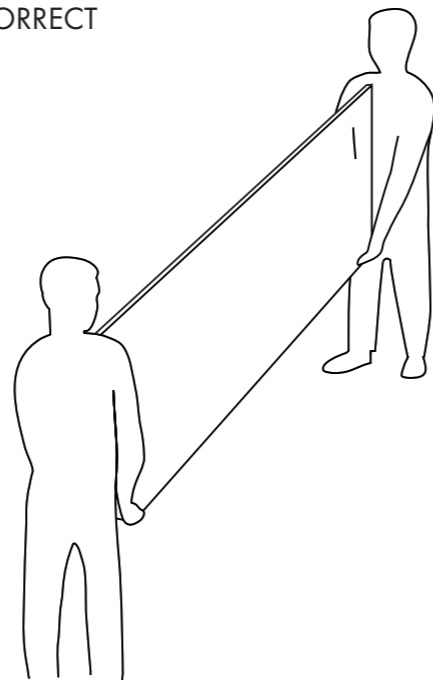

✔ CORRECT

2.3 TRANSPORT BY SUCTION FRAME

This is only recommended for 6 mm thick slabs. The suction cups may be placed all along the frame to adapt to the size of the piece to be moved. Using this tool is also recommended when installing the slab in its final location.

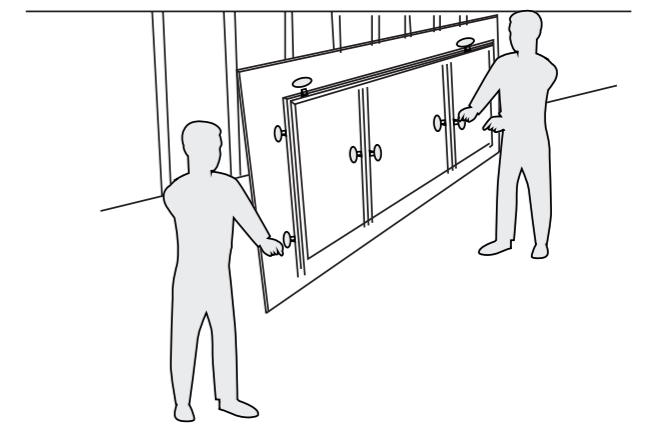
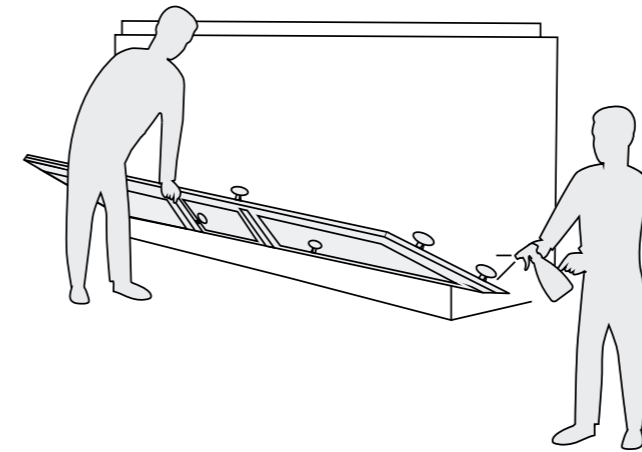
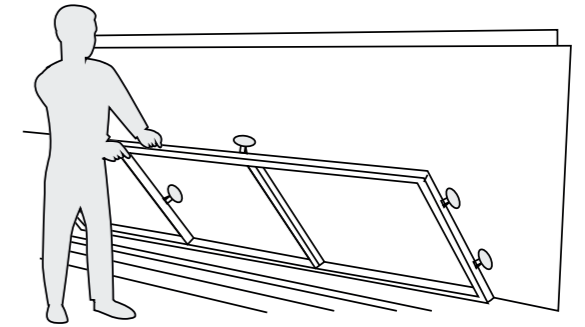

If this type of frame is not available, an aluminium rod or similar element, secured with several jacks, can also be used. This will prevent the piece from bending too much during handling.

Fixing thin, long pieces (skirting, for example) with jacks to an aluminium rod for transport is also recommended.

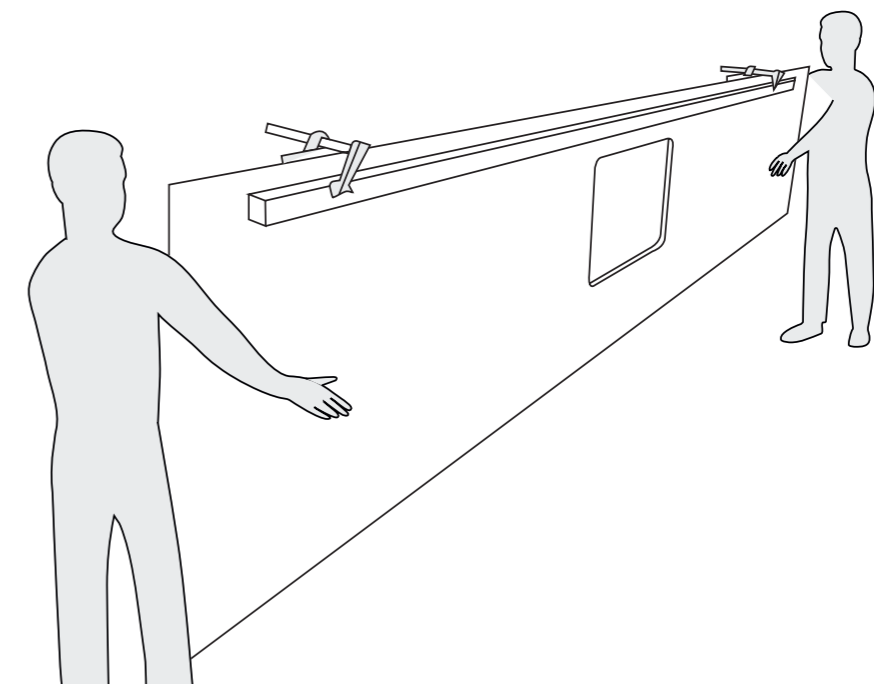

2.4 PACKING

After production, the slabs are placed on trestles which are ideal for transport and storage after proper labelling.



Trestles with Ascale slabs must be loaded, unloaded and moved using a proper lift truck, crane or other handling mechanism.

Whenever handling or moving, make sure the load is balanced.

If possible, keep your Ascale slabs on the same trestle they came on.

Any subsequent handling must be by using adequate trestles or rails (wooden or metal) with proper protection to vertically support the slabs (wooden, plastic or rubber) to prevent chips and dents at the support point.



2.5 STORAGE

When storing slabs on trestles not supplied by us, using a continuous support base or at least one with four support points for the slabs is recommended. This base must be rigid (preferably made of wood).

This will prevent splintering on the edges of the Ascale slabs.

Make sure the Ascale slabs have at least three support points (one in the middle and two on the sides).

If storing in the open air, cover the slabs with waterproof fabric.

The cut pieces may have sharp edges, so handle with care and adequate protection.

Cut material must be packaged with cardboard or similar protection on the corners and with shock absorbance panels on the perimeter edges (in adequate thicknesses) as protection against blows.

If the product is not packaged adequately, it may break.

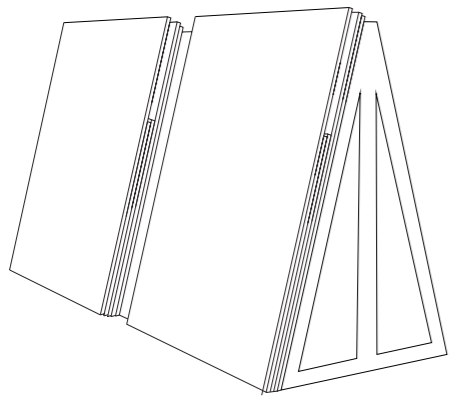
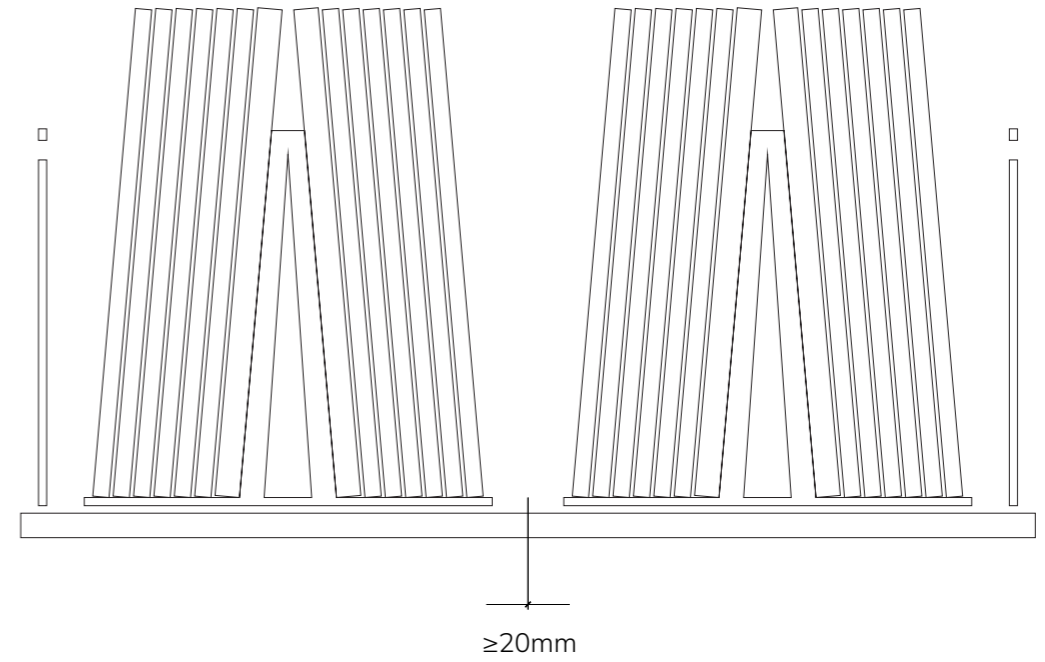

X INCORRECT

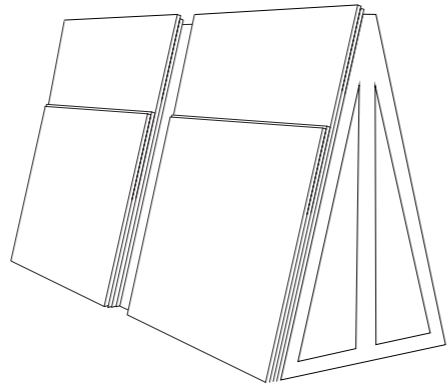

✓ CORRECT

"Avoid positioning large slabs against smaller slabs:"

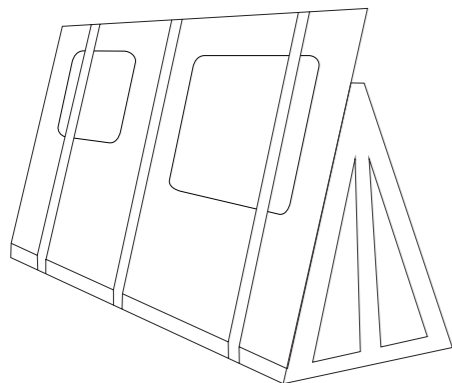

X INCORRECT

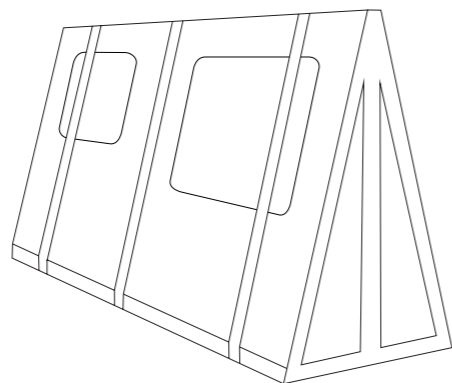

✓ CORRECT

"Likewise, check that the trestle or base on which the slabs are supported is larger than the slab surface"



Ascale controls the slabs in accordance with the highest standards of quality. Even still, always inspect the material received before starting any work by following these steps:

- Check the outside of the packaging (no visible blows or damages).
- Check that everything corresponds between the transport document, order and material received. The product code is printed on the side edges of each slab.
- Realice una inspección visual de la tabla para advertir posibles defectos superficiales: fisuras, manchas, destonificación, variaciones de brillo e imperfecciones. Una inspección a contraluz es altamente recomendada.

No claims will be accepted for installed or manufactured material when defects were already present upon delivery of the material. Marble workers are responsible for determining whether the slabs are adequate for use. If they are not adequate, the supplier must be contacted immediately so they may be exchanged before the slabs are cut or modified in any way.

ASCALE 183 AS.ANTALYA SAND 160X320 MATE 20MM 100 MADE IN SPAIN 8429991903107 H01

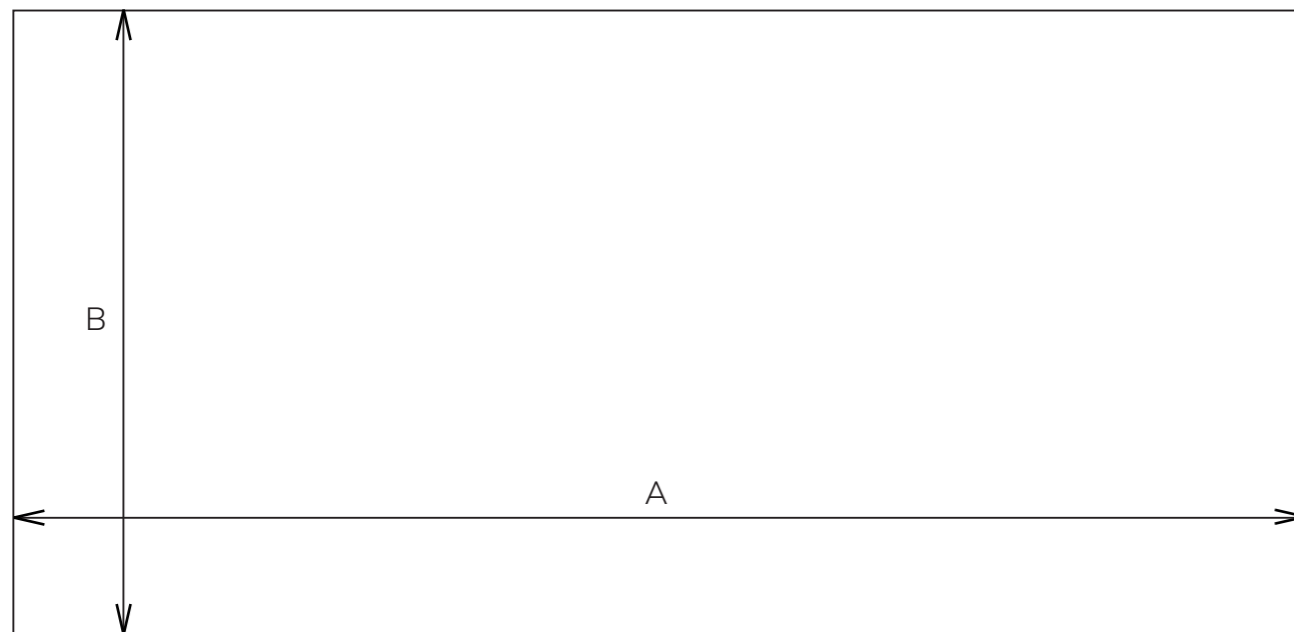

Dimensions	Length mm (A)	Width mm (B)
For guidance only	3240	1630
Useful for 6 mm	3197	1597
Useful for 12 mm	3200	1600
Useful for 20 mm	3200	1600

3.1 FLATNESS

To check the flatness of a slab, position it over a completely flat horizontal base free of any residue. Máxima tolerancia en la anchura y longitud de la tabla:



Convex planarity should be measured with an aluminium rod held parallel to one side to verify it. It is possible to assess the portion of the plate with possible bending by using a 2 mm thickness gauge. If the thickness gauge does not pass underneath, there is no planarity problem.

3.2 DIMENSIONS

The term 'Full Size' means that the board has finished the production cycle without being trimmed. This is the size intended to be processed, because it gives manufacturers the opportunity to optimise their possible cutting schemes according to the project.

The size 162 x 324 cm, which corresponds to the usable area and the billable quantity, can be obtained from each board.

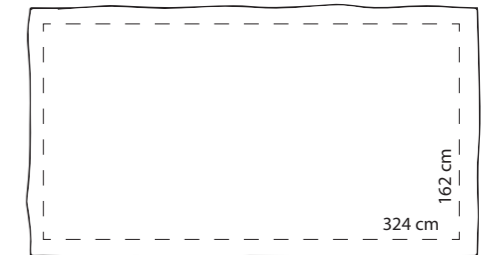

3.3 SLAB IDENTIFICATION

Each slab is affixed with a label indicating important information to ensure their traceability such as the model, tone and production date. Keep or record the label for future reference..





100



50

04 PRE-DESIGN RECOMMENDATIONS

Workspace: evaluating the logistics of the job is important as the installation of slabs with dimensions of 3200 x 1600 mm requires enough space for handling and installation.

Layout: due to the flatness, Ascale slabs may be installed following any diagram, even staggered with the seams offset by 50%.

L-cuts: avoid them whenever possible; use on surfaces with the smallest slabs or by adding seams. In fact, the supports and plaster at these points transmit stress and building settlement over time which can cause material to crack due to weakening caused

by the irregular cut. This phenomenon is not considered a material defect.

Material planning: when using large-size slabs, check the installation diagram and final formats to be installed to verify the quantity of material needed for the wall or floor tiling.

Always have extra material in case something breaks during the process or for future needs.

05 CUTTING AND WORKING WITH THE MATERIAL

Ascale slabs may be easily cut and perforated.

The most complicated cutting, profiling and hole-making operations can be done at specialist shops and centres with a disc saw, digital control machine, water jet cutter or other professional equipment available. See the Ascale "Countertop Technical Manual" for recommendations.

The easiest work with the material may be done directly on site. Use care when moving pieces and cutting. They can be used for dry and wet systems which are also used for glass, natural stone and porcelain tile. This means there is no problem with adjusting panel dimensions on site or making special cuts, holes, boxes, etc.

5.1 RECTILINEAR MANUAL CUTS

Normally used to adjust slab dimensions. Ascale 6 mm+ slabs are supplied rectified and squared which makes the work on site much easier.

The most common method is with dry glass cutters. This system is appropriate for making 6 mm+ tiles:

1. Mark the intended cutting line.
2. Secure the cutting rod over the visible side of the tile, firmly securing it and making sure the incision wheel is just over the cutting line marked.
3. Make a pre-incision in each one of the ends, 1-2 cm from the inside to the outside of the tile.
4. Make a complete incision from one end to the other without stopping and with a constant cutting speed and constant pressure.
5. Move the tile over the work bench, making sure the incision line exceeds the bench by 10-15 cm.
6. The slab will be almost cut already. Separate both sides of the cut with the clamps. Two people should do this together when the cut tile format is large.
7. Cut the reinforcement mesh with a cutter.
8. Remove any sharp edges, bevelling with diamond discs or abrasive sandpaper.

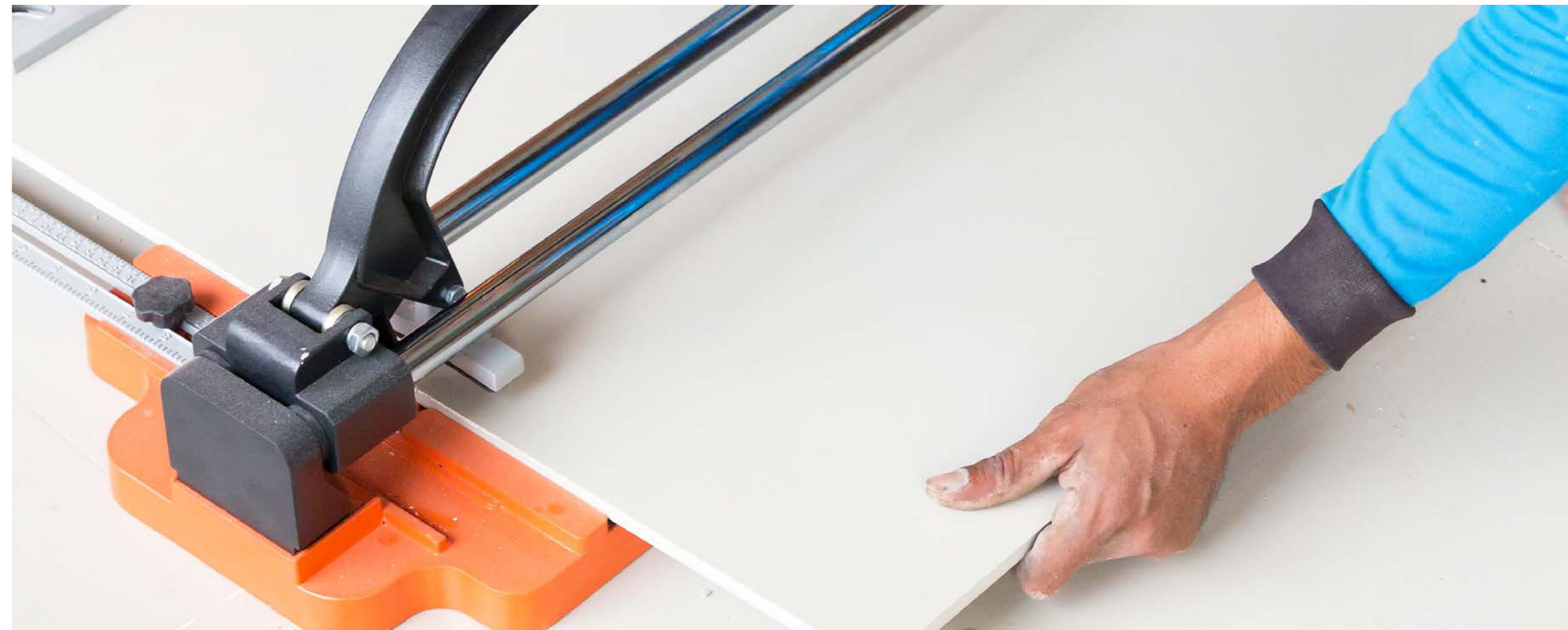

5.2 NON-RECTILINEAR MANUAL CUTS

Trace the cutting line with a pencil. Use a grinder with diamond bits to cut the tile. Making these types of cuts on site is recommended only when working on small jobs.

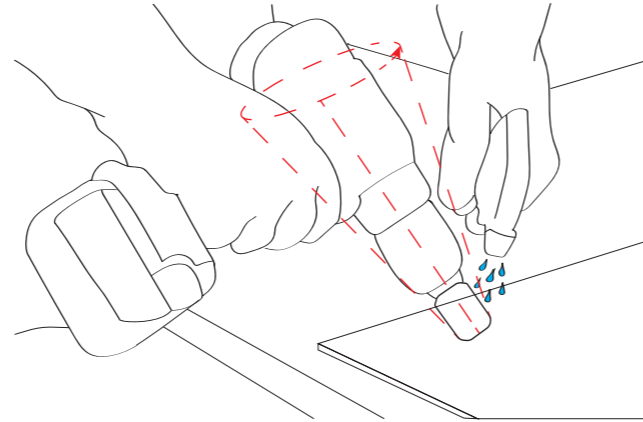

5.3 PERFORATIONS

Position the tile over a flat, stable surface.

Begin making the hole with a diamond crown bit with an angle of approx. 75° with respect to the slab.

Make the hole by carefully swaying the tool, making sure the cutter constantly cools down.

5.4 L-CUTS AND BOXING

These are critical points. Doing them correctly will prevent breakage and cracking.

Leave a radius of more than 3 mm in any inner L-cut. The bigger the radius, the stronger the piece will be. For these points, also respect the corresponding seams indicated on the successive points.

Position the tile over a flat, clean and stable work surface.

The holes for electrical sockets must be opened at a minimum distance of 5 cm from the tile edges. Once the hole measurements are delineated, begin perforating on the visible side of the tile. Make drill holes (without the hammer mode) with diamond cutters (diam. 6-10 mm), swaying the drill and making sure the tool is constantly cooled with water.

Make the holes in the four corners. To open the hole, make straight cuts between the holes with a diamond disc cutter with a small diameter.

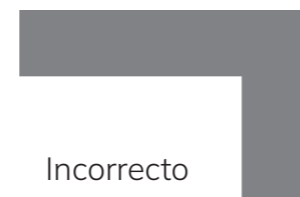
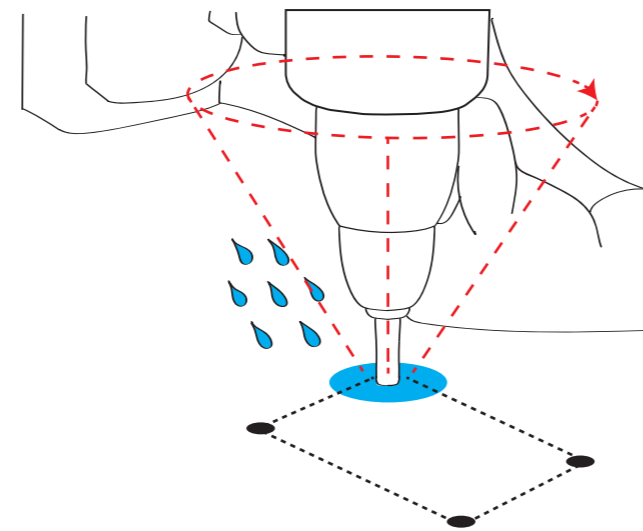

6.1 PRELIMINARY CONSIDERATIONS

The support on which the slab will be installed is of vital importance to proper installation and proper functioning of the wall tile over time. Before beginning the installation, check that the support has these characteristics:

1. It is dry and the surface is free of paint, grease, resin, dust and, in general, any loose particle.
2. It is compact and has the mechanical resistance required for the intended use.
3. It is stable after completely setting and settling. There must not be any cracking. For unstable supports and floor slabs or any with light fissures, using an anti-fracture mesh between the support and the tiling is recommended.
4. It is flat. To install large-format Ascale slabs, fill in the level differences using adequate levelling products.
5. It has been made with the necessary perimeter and expansion joints.

6.2 APPLYING ADHESIVE

Handling Ascale slabs with suction frames will be necessary in most cases. Check that the suction cups are tight before moving the slabs. Cleaning and dampening the suction cups before attaching them increases the attachment to Ascale slabs.

To apply fast-drying cement, position the slab fixed to the suction cup frame, rotating the slab facing down. A flat work bench will be required where the frame can rest without deforming or arching the slab. Once the slab is secured in a horizontal, flat position, the back of the slab must be cleaned to remove any dirt that may affect the adhesive adherence.

6.3 DOUBLE GLUING

Adhesive must be applied using the double gluing technique; in other words, on the back of the Ascale slab and on the support.

Using a 3-4 mm flat notched trowel on the back of the slab is recommended. Then, use a 10 mm slanted notched trowel with the support. Try to cover all corners and edges and avoid air pockets between the support and the piece of slab.

Position the slab in the desired location and hit the slab with a rubber hammer to remove all encapsulated air between the layers of adhesive. For best results, extend the adhesive on the tile and on the support with the trowels in the same direction, preferentially parallel to the shortest side of the slab to make it easier to get all air out when hitting with the hammer.

Double gluing is necessary so the tension caused by support expansion and movement is evenly distributed over a larger area.

6.4 JOINTS

Ascale slabs in 6 mm thickness are supplied rectified. Added to the low thermal expansion in the material, this means thick joints between pieces and at meeting points with other construction elements are not necessary. Even still, the installation of joints is necessary to prevent breakage or unsticking due to the behaviour of the support. There are several types of joints:

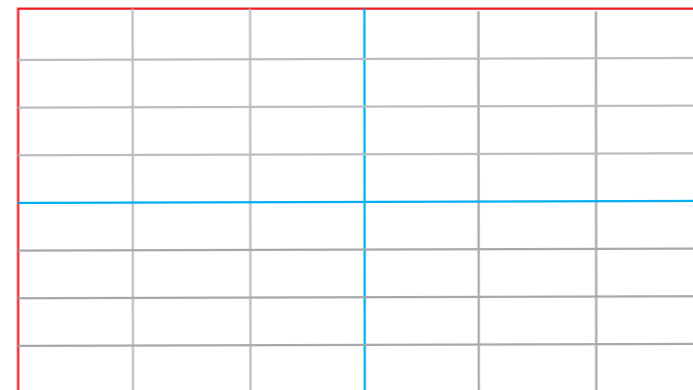

LEGEND

Grey: Installation joints

Blue: Expansion joints

Red: Perimeter joints

As an expansion joint, an empty space of at least 3 mm must be provided between the product and the wall against which it rests, and approximately 1 mm between juxtaposed boards during construction.

Due to the nature of Ascale boards, a micro bevel is recommended for all joints.

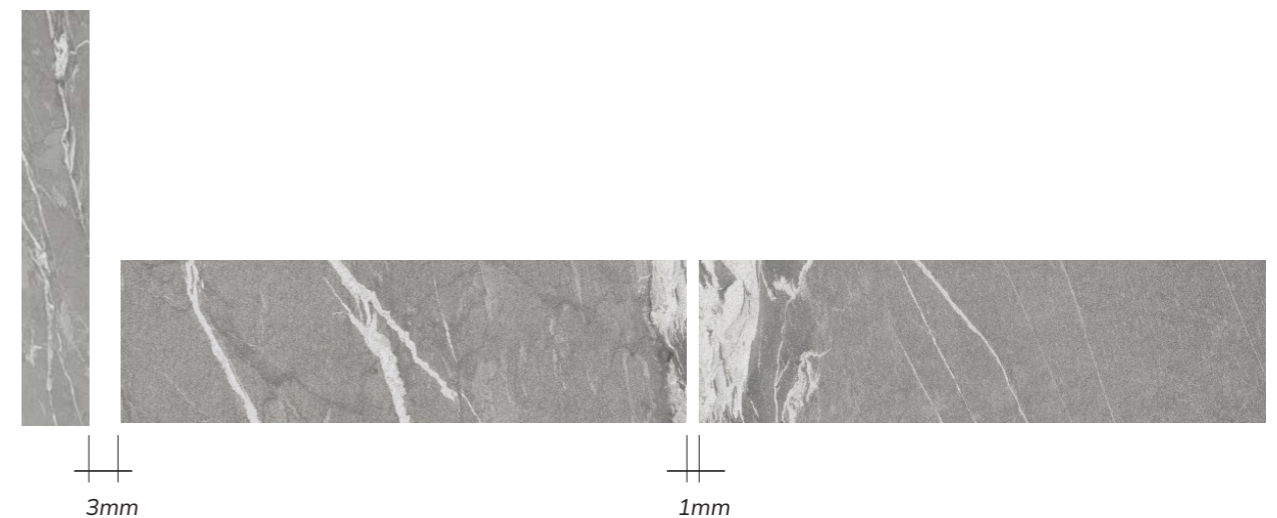

6.5 GROUT LINES OR INSTALLATION JOINTS

Or the habitual joints between two Ascale pieces. Necessary to absorb the tension transmitted to the wall tile and spread the steam in the lower strata of the system. They must be 2-3 mm thick in interiors and at least 5 mm thick outdoors, whenever the support is stable.

6.6 EXPANSION OR AREA JOINTS

Joints that only affect the wall tiling, designed to divide the total area to be tiled into smaller regular sub-areas to absorb the expansion and contraction of Ascale tiles. For indoor floor tiling, they must be at least 5 mm thick and delimit a maximum area of 40 m².

For outdoor floor tiling, they must be at least 8 mm thick and delimit a maximum area of 12 m².

Expansion joints must also be used in door passages and thresholds, coinciding with the floor slab joint. Even in contiguous rooms where there is a change in flooring, different tensions may arise in the floor slab. Therefore, an expansion joint is necessary.

6.7 PERIMETER JOINTS

Necessary for changes in plane and in the perimeter boundaries of the areas to be tiled; they minimise the transmission of tension between different construction elements that work together.

For flooring, these joints affect the wall tiling as well as the thickness of the mortar expansion while they may only affect the wall tiling on walls. In any case, any perimeter joints must be at least 8 mm thick.

6.8 STRUCTURAL JOINTS

They're the ones in the building structure which not only cross through the structure but also the rest of the layers of the system (wall tiling, adhesives, insulation layers and decoupling layers, etc.) meaning they must also be respected with Ascale slabs. They must normally be finished off with a metal profile or elastic sealant.

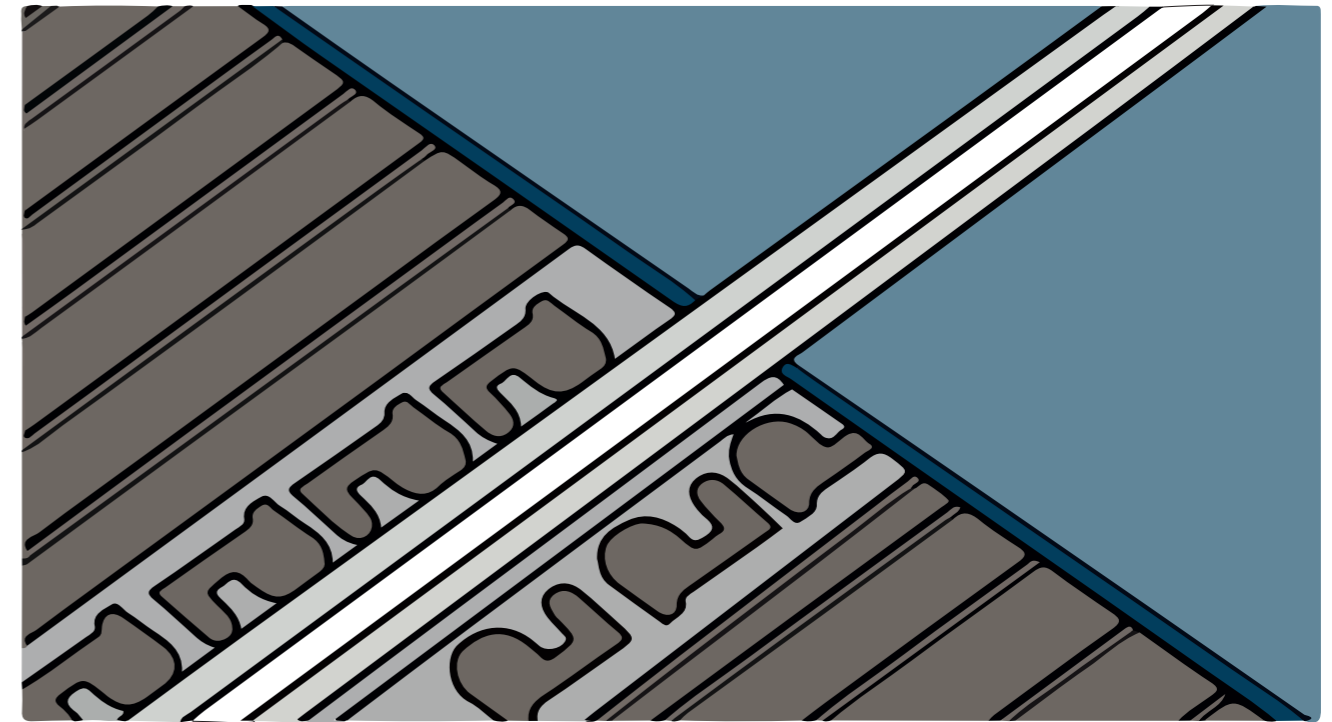
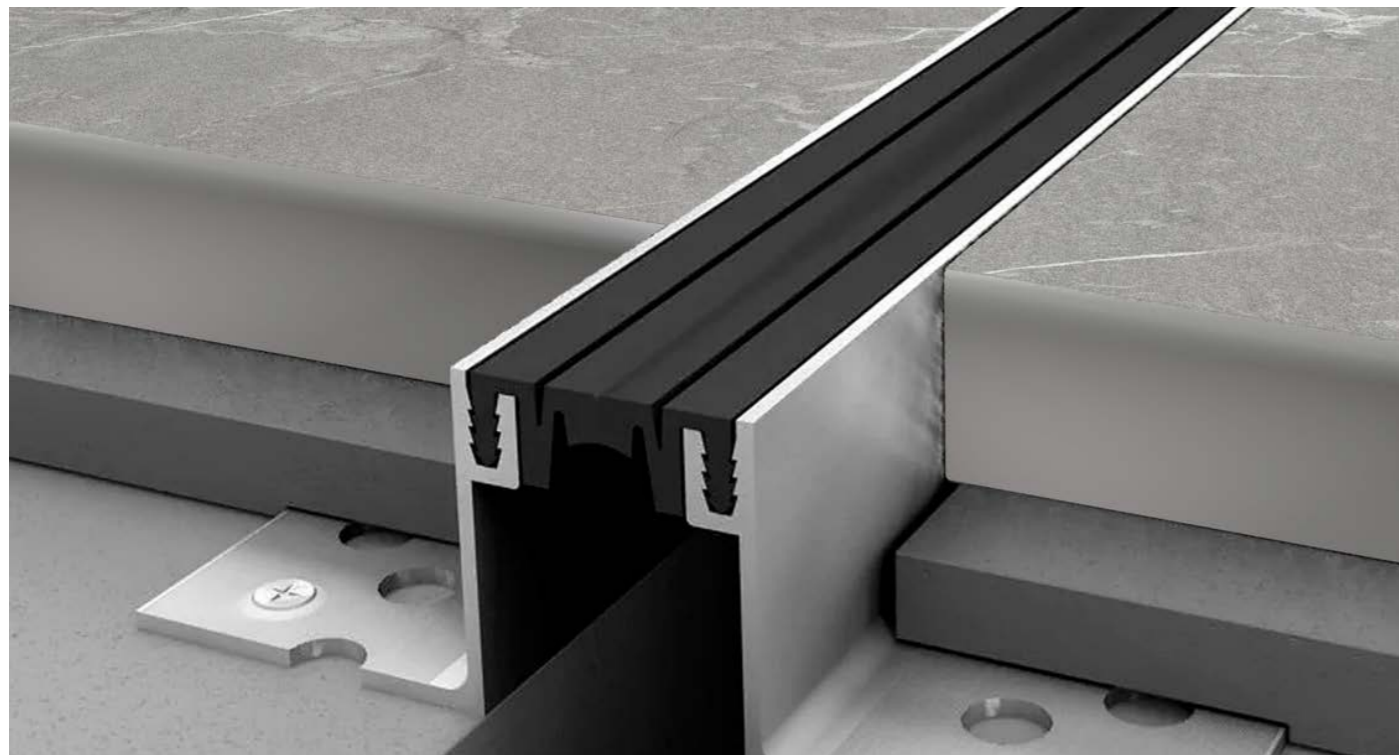

6.9 LEVELLING SYSTEMS

They are of special importance for large-format tiling to get completely flat and even finishes. There are several advantages to these systems:

- They help achieve levelled floor tiling
- They ensure the Ascale slabs are firm against the support
- They reduce the slab installation time



Levelling process:

1. Install the levelling supports: once the adhesive is spread, place the plastic supports under the piece all along the sides of the piece. For large-size pieces, more than one support per side is recommended.
2. Position the floor tile and insert the wedges in the support groove, being careful not to break them. Now, you can check the exact levelness of the floor tile with a level. If not correct, adjust by putting pressure on it with the corresponding wedges.
3. Let the adhesive completely set and remove the supports, separating the part that sticks out of the base with a slight crosswise blow.

Grouting material is no less important when installing floor tiling which may end up ruining a good installation otherwise both aesthetically or functionally.

The choice of grout depends on the conditions to which it will be exposed:

- Mechanical characteristics: adherence, deformability, resistance to traction, compression and bending
- Material behaviour: water absorption, steam diffusion capacity, resistance to abrasion, fire, frost/thawing cycles
- Surface characteristics: uniform colour and texture, chemical resistance, stain resistance, mould resistance

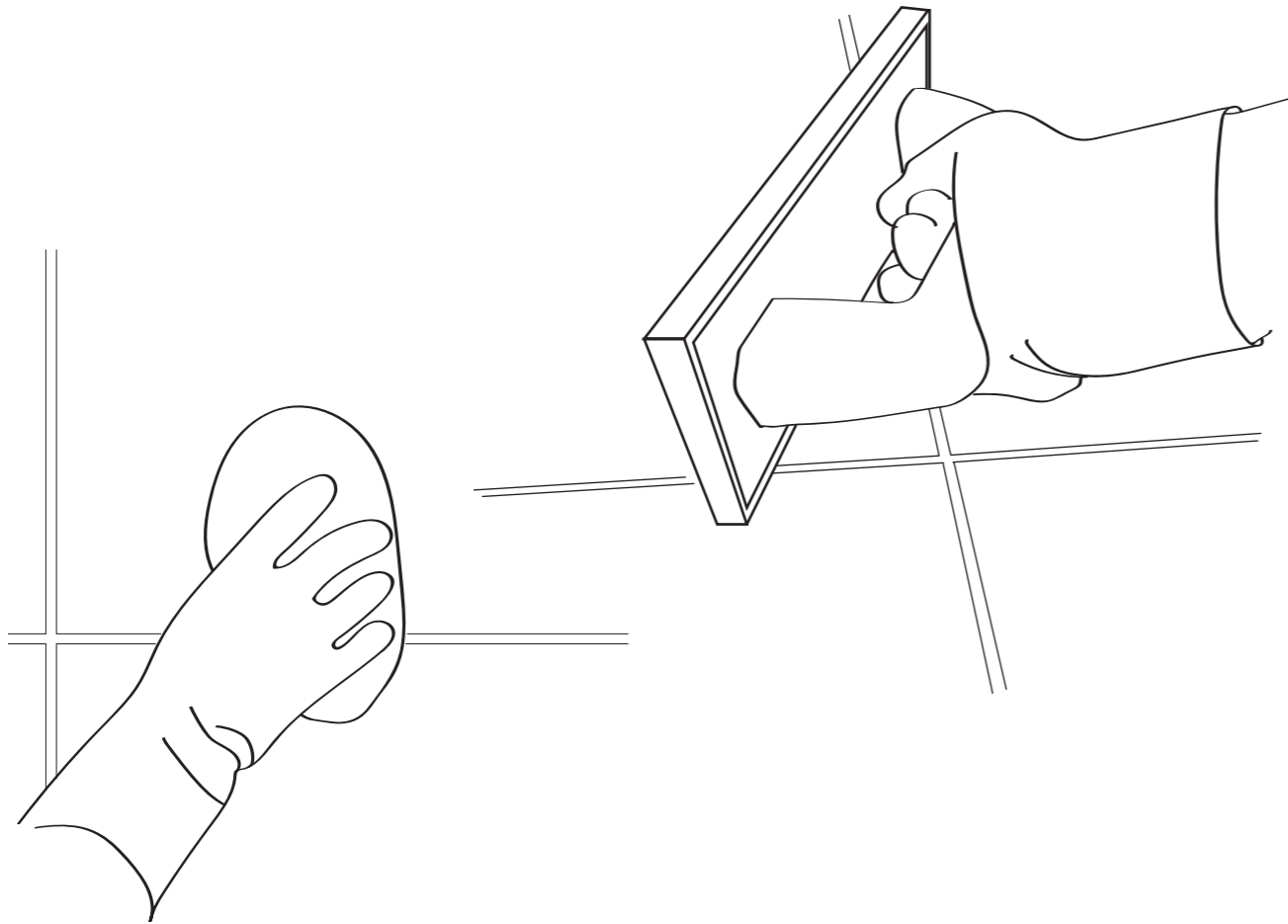

7.1 CEMENT-BASED GROUTING PRODUCTS

Recommended for most applications. Grouting that is high-performance, anti-mould, antifluorescence, quick fix and dry, water-repellant, class CG2 as per EN 13888 is recommended.

Application

Before applying the grouting, dampen the surface around the joint with a wet cloth or a sponge using a minimal quantity of water so the joints remain dry. Then, completely fill the joints without leaving any gaps using a 45° trowel. Remove any excess grout from the tile surface.

Cleaning

Begin cleaning as soon as the grout begins hardening (generally 10-30 minutes). Do not let any grout remain on the tile surface for much time before completing the initial cleaning.

Use the lowest quantity of water possible to clean the grout from the surface. Any excess water will discolour the joints.

After cleaning each time, rinse and squeeze the sponge so no excess water remains on the slab surface or in the grouted joint.

Change the rinse water frequently. Make sure all slabs are well-cleaned before the grout dries. Clean the surface again around an hour later with a clean rag to remove any remains. If there is still some grout on the slabs because it wasn't cleaned correctly, you can use a cement remover but no earlier than 24 hours after grouting.

7.2 REACTIVE RESIN GROUTING PRODUCTS

Application

Apply to dry joints with a rubber trowel, making sure the joints are completely filled.

Remove any excess material with the same trowel diagonally, leaving only a fine film of excess on the piece.

Cleaning

Epoxy grout or reactive resins must be cleaned when wet. Dampen the grouting surface and rub with a sponge rather hard in circular movements to soften the grout film and remove it.

Replace the sponge when very impregnated with resin. This is important because hardened grout remains are difficult to remove.

You can do a final cleaning with special cleaners for epoxy grout even several hours after application.

08

BONDING PRIMER

These are products that enhance the adherence between the adhesive and the support or piece for better adherence results than theoretical results simply with adhesive.

Apply the bonding bridge directly on the back of the Ascale piece in a fine film, preferably using a sponge roller in one direction and repeating the operation by crossing back over.

Wait for the product to dry completely before continuing to install the piece



09

ADHESIVES

Ascale panels in 12+ and 20+ thicknesses generally do not require reinforcement with other materials.

It may be necessary to glue the slabs together mainly if there is a perimeter panel, to create an infill and a uniform horizontal surface. When bonding Ascale slabs to worktops, adhesives are used, the colour of which is compatible with the colour of the mass of the Ascale material used. It should be noted that on some of the Ascale models, the colour of the surface is not exactly the same as that of the slab body.

This is important as, when polishing the edges, the colour of the mass is exposed. The various manufacturers of adhesives for this use recommend their own products, which are as close as possible to the colours of the Ascale models.

For more information on suitable colours, please consult your sales representative or your adhesive supplier. The choice of gluing material, the glue to be used and the frequency of application are at the discretion and under the responsibility of the installer, and must be verified according to the conformity of the worktop, the materials used and the intended use of the worktop.

ASCALE