



ASTALE

Technical Manual

Read the guide on how our plates work and how to maintain them correctly to avoid potential problems.





1. Product

- 1.1 Formats and thicknesses
- 1.2 Colour range
- 1.3 Finishes
- 1.4 Certificates

2. Handling and storage

- 2.1 Handling slabs
- 2.2 Packing
- 2.3 Manual transport
- 2.4 Transport using a frame with suction cups
- 2.5 Storage

3. Reception and quality controls

4. Machining parameters

- 4.1 Cutting with a disc cutter
- 4.2 Parameters for CNC tools
- 4.3 Manual work
- 4.4 Waterjet parameters

5. Countertop design recommendations

- 5.1 Design and shapes
- 5.2 Planning
- 5.3 Joints
- 5.4 Designing holes for sinks and hobs
- 5.5 Sinks and hobs
- 5.6 Edges
- 5.7 Substructure and installation
- 5.8 Reinforcements
- 5.9 Overhangs

6. Heat

7. Adhesives

8. Cleaning, maintenance and usage precautions

9. Safety data sheet



1. PRODUCT

Introduction

Pamesa Group has always been focused on the achievement of wellbeing in architectural spaces and excellence has been obtained in that regard with Ascale: an all-new multi-purpose, large-sized and lightweight material. Pamesa Group is re-inventing itself and adapting architectural spaces to new lifestyles. The value of a brand along with work, effort, innovation and quality keep the industry alive. Ascale strengthens the technical characteristics of top-of-the-line wall tile with more possibilities due to its lightness and adaptability.

Using high pressure and temperature, we transform 100% all-natural mineral into slabs that combine natural beauty with resistance from the latest technologies.

Ascale is the latest generation of sintered stone, with dimensions of 162x324 cm (which we present in 12 and 20 mm formats), 160 x 320 cm (which we present in a 6 mm format), and dimensions of 120 x 280 cm in certain series of our collection. Ascale offers a wide variety of 12 and 20 mm thick slabs, which allow the construction of any work surface, and complements these thicknesses with lighter slabs, 6 mm thick, which can be used to cover any vertical or horizontal paving.

The combination of both thicknesses, 6 and 12 mm, makes Ascale a powerful tool at the service of architecture, interior design and construction professionals, as it allows the creation of unique, elegant and versatile spaces, with the unbeatable technical performance offered by the material.

Product

Why use Ascale? Because our sintered stone offers the ideal technical characteristics for any work surface to get the same or even better aesthetic value than with any other material.

Our collections perfectly adapt to the needs of all types of people. We have all types of marble, cement, stone, wood, metal and basic colours. Our mission is to create areas that evoke feelings of comfort wherever they may be.

Thanks to Ascale, you can enjoy the most iconic natural stone finishes with the features of next-generation slabs. Moreover, our 6 and 12 mm slabs feature a fibreglass mesh reinforcement on the back so the material can attain the highest possible resistance.

1.1 Formats and Thicknesses

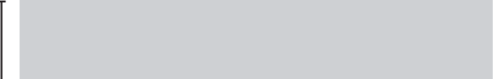
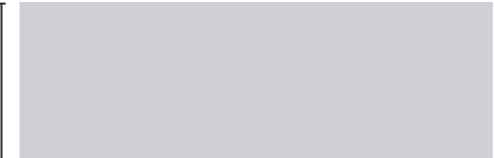

	6 mm	12 mm	20 mm
6 mm - 1/4" 	•		
12 mm - 1/2" 	•	•	•
20 mm - 3/4" 	•	•	•
Indoor wall tile	•		
Indoor floor tile	•	•	•
Outdoor floor tile	•	•	•
Façade	•	•	
Exposed anchorage ventilated façade	•	•	
Concealed anchorage ventilated façade	•	•	
Countertop		•	•
High-traffic floor tile	•	•	•
Indoor wall tile over material	•		
Indoor floor tile over material	•		
Furniture	•	•	



1.2 Colour range



BORGOGNA
SILVER



ARIZONA
SAND



ETNA
BLACK



URBAN
WHITE



CARDOSO
GRAY



TIVOLI
WHITE



ALLURE
BLACK



MONTBLANC
WHITE



ARMANI
SILVER



BELVEDERE
BLACK



MACCHIA-
VECCHIA GOLD



CROTONE
PULPIS



ARABESCATTO
WHITE

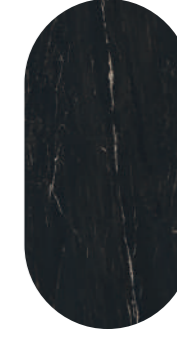

MARQUINA
BLACK



PALOMASTONE
LINEN



MOON
BLACK



NEBULA
BROWN



COSMOPOLITA
IVORY

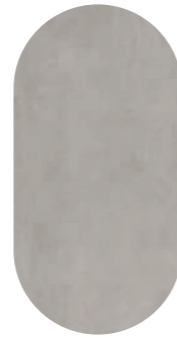

COSMOPOLITA
SILVER



COSMOPOLITA
GRAY



BOREAL
UMBER



GRASSI
WHITE



TAJ MAHAL
ALMOND



LUCCA
GOLD



NEW TORANO
STATUARIO

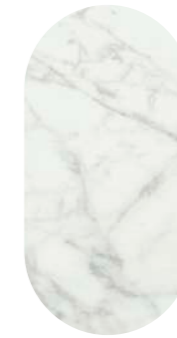

VAGLI
GOLD



DUCAL
GOLD



CRYSTAL LUX
WHITE



BOREAL
SAND



MILLENIUM
COPPER



LABRADORITE
ROYALBLUE



AMAZONITE
SEAGREEN



PATAGONIA
GOLD



ONICE
BLUE

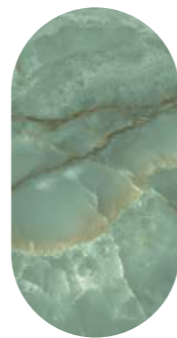

ONICE
SEAGREEN



LASA
WHITE

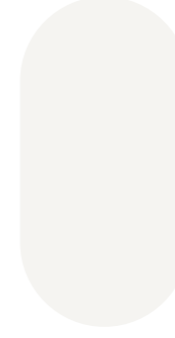

ALPI
WHITE



GRUM
BLACK



ONICE
BLACK



ONICE
LUX WHITE

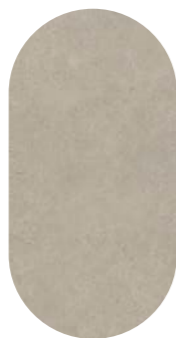

ANTALYA
SAND



CEPPO DI
GRE

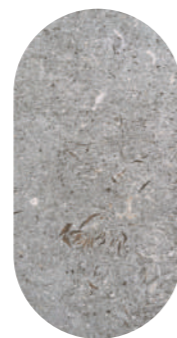

DUNE
GRAY



PIERRE
BLUE

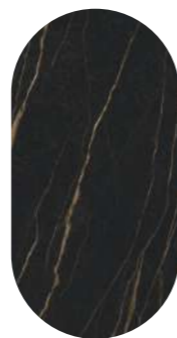

LAURENT
BLACK



1.2 Finishes

POLISHED • VELVET • FEEL • MATT

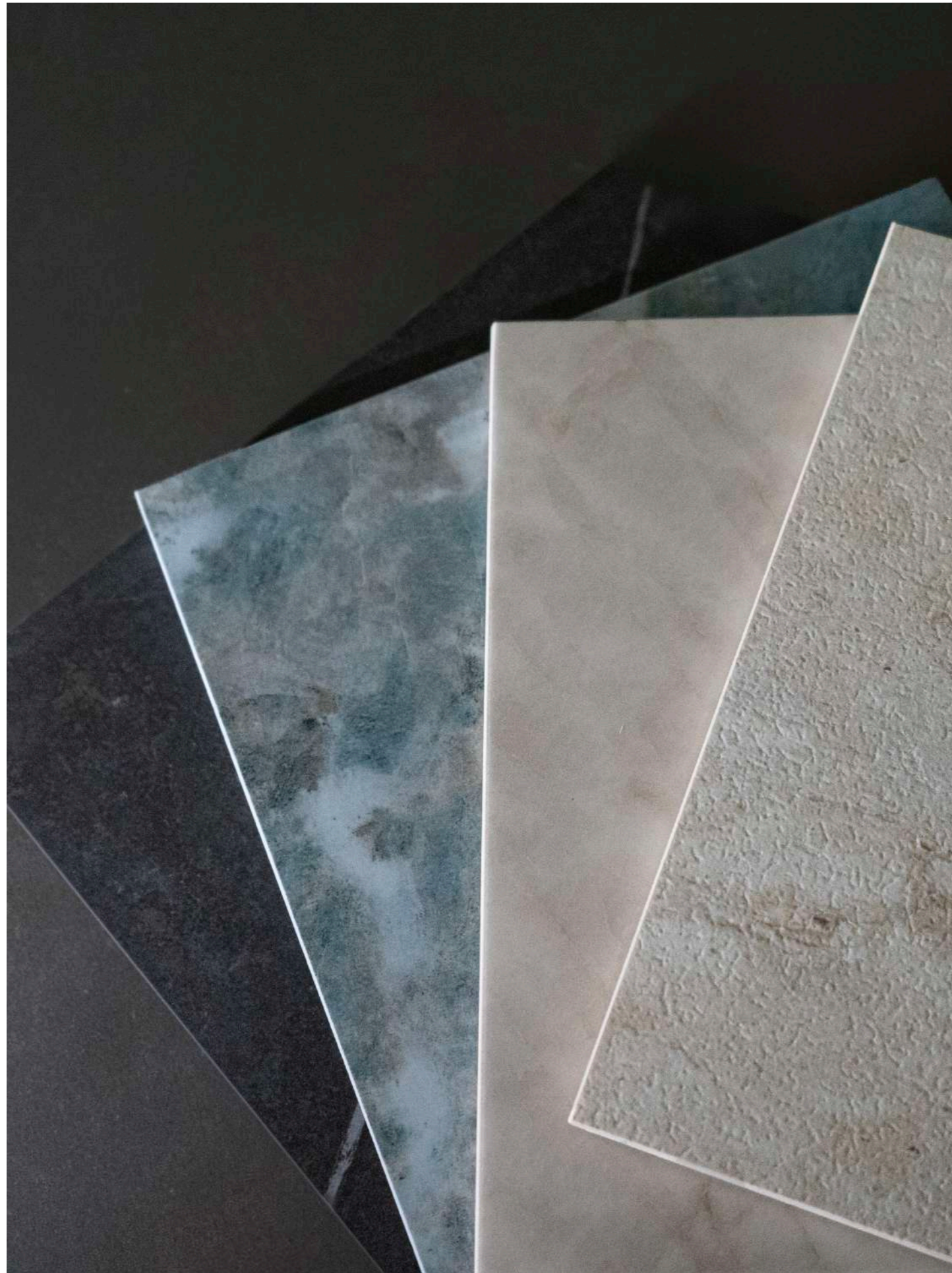

FORMAT

162 x 324 (12 y 20 mm) | 160 x 320 (6 mm) | 120 x 280 (6 mm)

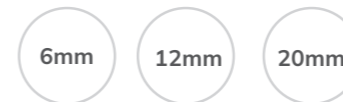
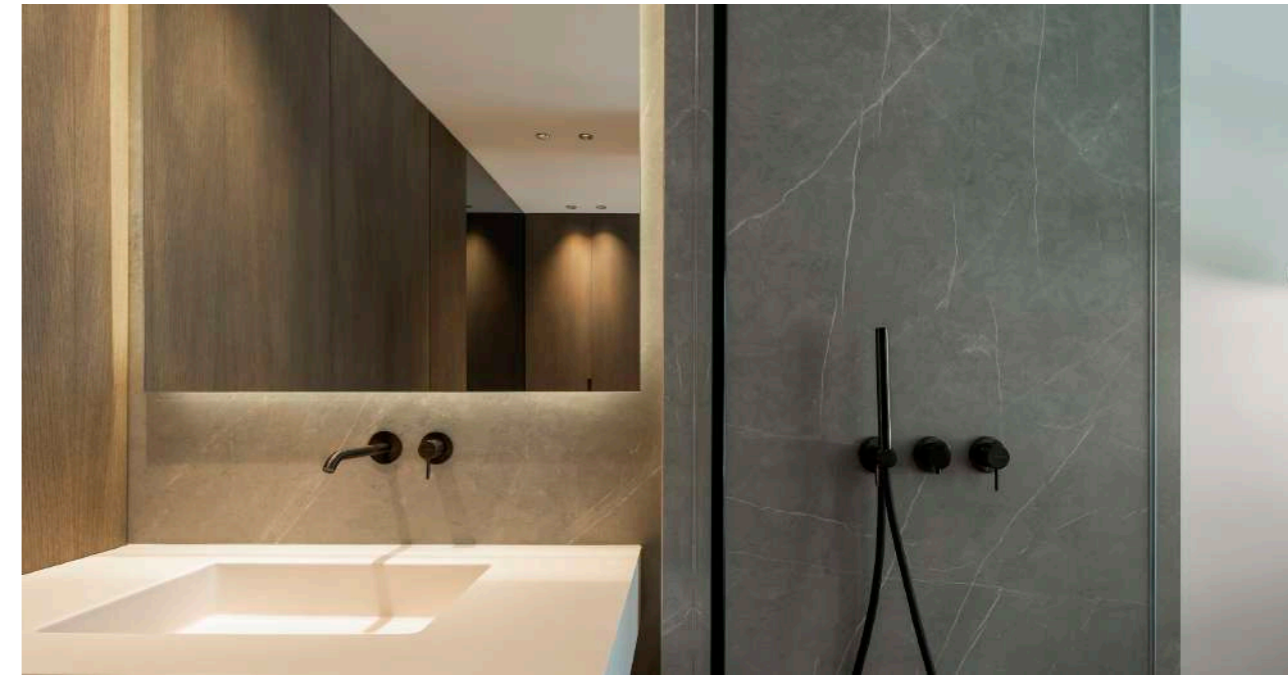

6mm	<p>WALL TILE: Interior and outdoor.</p> <p>FAÇADES.</p> <p>FLOORING: Interior and outdoor</p> <p>FURNITURE.</p>
12mm	<p>COUNTERTOPS: Kitchen and bath.</p> <p>FLOORING: Outdoor.</p>
20mm	<p>COUNTERTOPS: Kitchen and bath.</p> <p>FLOORING: Outdoor.</p>



1.4 Certificates

Seguridad / Medio ambiente / Calidad

- Ascale Tech ISO 9001



- Ascale Tech ISO 14001



- Certificate CCC Ascale Elite



- Environmental declaration



- CRC certificate



- SASO Certificate of Conformity



- Indoor air quality (IAQ) certificate





Sustainable development



Ascale has an environmental management system to identify and minimize the impact of its operations on air emissions, wastewater, waste and noise pollution. Integrated Management System (SIG), designed by Ecoembes and aimed at the selective collection and recovery of packaging waste for treatment, recycling and assessment.

The company has Environmental Product Declarations (EPDs) for all the product families it markets. A declaration granted in 2014 and extended in 2015 that highlights environmentally friendly products.

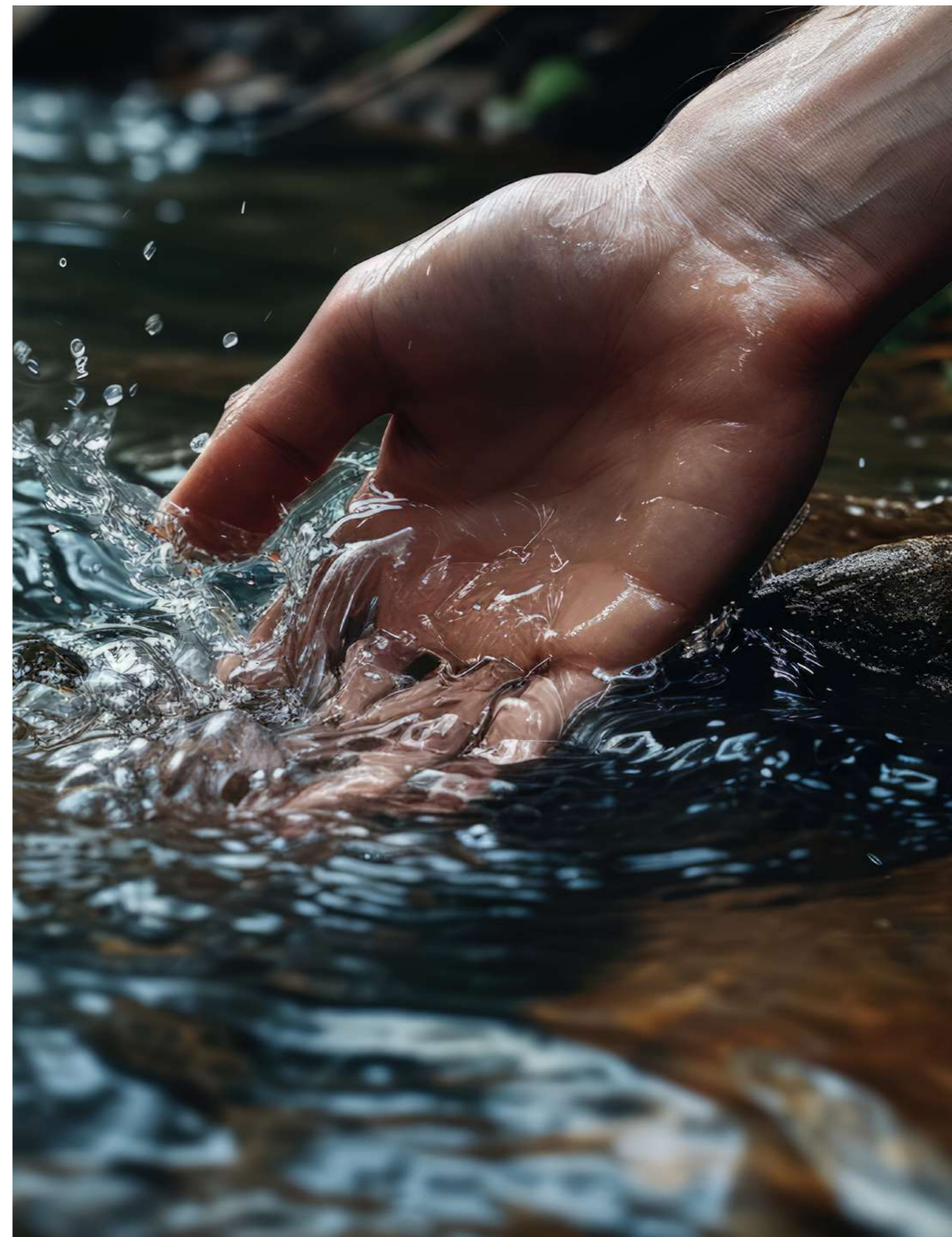

Ascale is committed to the optimisation of water management, based on the principles of reuse and optimisation of water in different processes. It is also committed to the constant application of energy efficiency criteria in its facilities and activities.



GRUPO BIa (GL) / GROUP BIa (GL)

PROPIEDADES FÍSICO -QUÍMICAS PHYSICAL-CHEMICAL PROPERTIES	NORMA DE ENSAYO STANDARD TEST	VALOR REQUERIDO REQUIRED VALUE	VALOR MEDIO AVERAGE VALUE
Espesor Thickness	ISO 10545-3	Cumple/Complies	Cumple/Complies
Absorción de agua Water absorption	ISO 10545-3	≤ 0,5%	≤ 0,1%
Fuerza de rotura Breaking strenght	ISO 10545-4	≥ 700 N e<7,5 mm ≥ 1300 N e≥7,5 mm	≥ 1000 N e=6mm ≥ 3000 N e=8mm ≥ 5000 N e=12mm ≥ 11000 N e=20mm
Resistencia a la flexión Modulus of rupture	ISO 10545-4	R ≥ 35 N/mm2	≥ 50 N/mm2
Resistencia al impacto Impact resistance	ISO 10545-5	Valor declarado Declared value	>0,8 sin defectos visibles / no visible defects
Resistencia a la abrasión superficial Resistance to surface abrasion	ISO 10545-7	Valor declarado Declared value	Valor declarado Declared value
Dilatación térmica lineal Linear thermal expansion	ISO 10545-8	Valor declarado Declared value	5,7.10-6°C
Resistencia al choque térmico Thermal shock resistance	ISO 10545-9	Resistente Resistant	Resistente Resistant
Expansión por humedad Moisture expansion	ISO 10545-10	Valor declarado Declared value	<0,1 mm/m
Resistencia al cuarteo Crazing resistance	ISO 10545-11	Resistente Resistant	Resistente Resistant
Resistente a la helada Frost resistance	ISO 10545-12	Resistente Resistant	Resistente Resistant
Resistencia química: productos de limpieza Chemical resistance: Cleaning products	ISO-10545-13	B	A
Resistencia química: Aditivos piscinas Chemical resistance: Swimming pool salts	ISO-10545-13	B	A
Resistencia química: Ácidos de baja concentración Chemical resistance: Low concentration acids	ISO-10545-13	Valor declarado Declared value	LA acabado mate LB acabado pulido
Chemical resistance: Low concentration bases	ISO-10545-13	Valor declarado Declared value	LA acabado mate LB acabado pulido
Resistencia a las manchas Resistance to stains	ISO 10545-14	Min.3	Min. 5 acabado mate Min. 4 acabado pulido
Emisión de plomo y cadmio Determination of lead and cadmium	ISO 10545-15	Valor declarado Declared value	Cadmium < 0,01 mg/l Lead < 0,1 mg/l
Resistencia al calor seco Dry heat resistance	EN 13310	Declared value	Resistente Resistant
Resistencia UV UV Resistance	DIN 51094	Declared value	Sin cambios No change



Advantages



LIGHTNESS

LIGEREZA / LÉGÈRETÉ / LEICHTIGKEIT



MADE IN

FABRICADO EN / FABRIQUÉ EN / HERGESTELLT IN



WATERPROOF

IMPERMEABLE / IMPERMÉABILITÉ / WASSERDICHT



CUT RESISTANCE

RESISTENCIA AL CORTE / RÉSTANCE AU CISAILLEMENT / SCHERFESTIGKEIT



RECYCLED

RECICLADO / RECYCLAGE/ RECYCLING



LARGE FORMAT

GRAN FORMATO / GRAND FORMAT / GROSSES FORMAT



100% NATURAL

100% NATURAL / 100% NATUREL / 100% NATÜRLICH



UV RESISTANCE

RESISTENCIA RAYOS UV / RÉSTANCE AUX UV / UV-BESTÄNDIGKEIT



HIGH RESISTANCE

ALTA RESISTENCIA / HAUTE RÉSTANCE / HOHE WIDERSTANDSFÄHIGKEIT



HYGIENIC

HIGIÉNICO / HYGIÉNIQUE / HYGIENISCH



LOW TEMPERATURES RESISTANCE

RESISTENCIA A BAJAS TEMPERATURAS / RÉSTANCE AUX BASSES TEMPÉRATURES / NIEDRIGE TEMPERATURBESTÄNDIGKEIT



HIGH TEMPERATURES RESISTANCE

RESISTENCIA A ALTAS TEMPERATURAS / RÉSTANCE AUX HAUTES TEMPÉRATURES / HOHE TEMPERATURBESTÄNDIGKEIT



STAIN RESISTANT

ANTIMANCHAS / ANTI-SPOTS / ANTI-SPOTEN

2. HANDLING AND STORAGE

2.1 Handling Slabs

Technical information	U.M.	6 mm	12 mm	20 mm
Slab surface	m ²	5,12	5,12	5,12
Slab weight	kg	77	152	253
Weight per m ²	kg	14	29	48
Slabs per trestle*	nr.	44	22	14
net m ² per trestle	m ²	232,32	116,16	71,68
Metal trestle weight	kg		210	
Full trestle weight	kg	3388	3344	3752
Dimensions of trestle including packaging	mm	3300 x 750 x 1900		

Transport with clamps

This is the best way to move 12 and 20 mm thick Ascale slabs. Always pay attention to the movement and handling of the slabs to prevent splintering or breakage.

Ascale recommends using the following type of clamp for lifting and moving individual slabs:

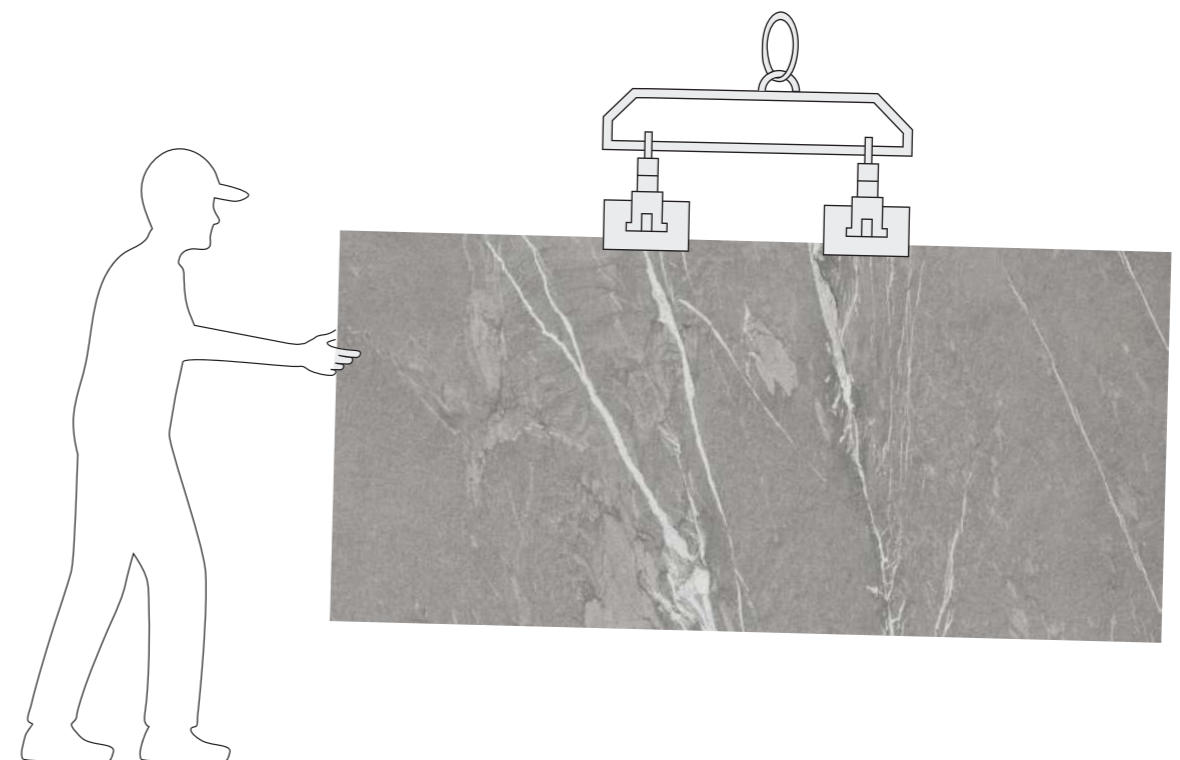

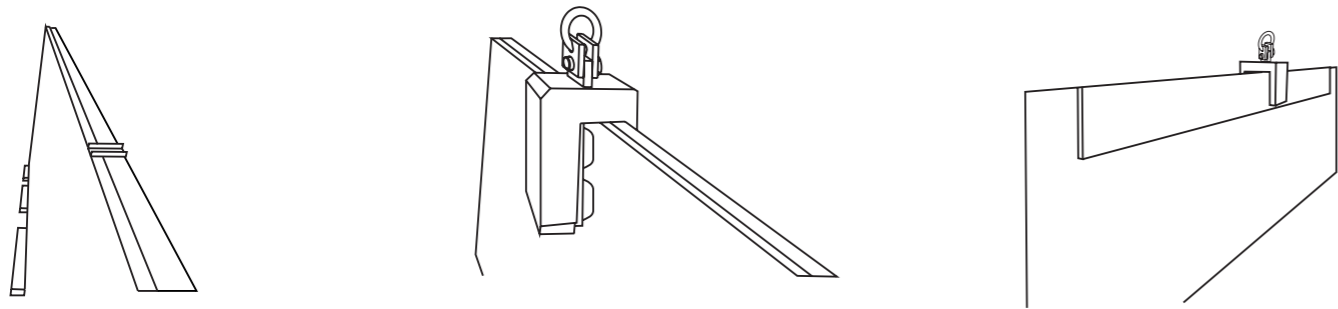

The additional width of this clamp will prevent the slab from bending during handling and prevent unwanted breakage.

Recommendations:

- Clamping more than two slabs at the same time is not recommended.

Make sure to cover all metal surfaces that may come into contact with the slab using adhesive foam tape.

If this type of clamp is not available, use a 2 cm thick plank of approximately 3 m x 20 cm so the clamp can carry 12 mm slabs.

Fixing the ends of the slab to the plank with jacks to prevent the slab from sagging during handling is recommended.

Position the plank to the rear of the slab to be lifted.

- 1) Place the clamp on the slab and plank.
- 2) Fix the clamp and lift the slab and plank with care.
- 3) Avoid sudden changes in direction.

Transport with slings

An adequate system for moving several slabs at the same time. Using canvas slings is recommended.

Metal slings should not be used to handle Ascale slabs. Using wooden spacers is recommended to prevent direct contact between the slings and slabs.

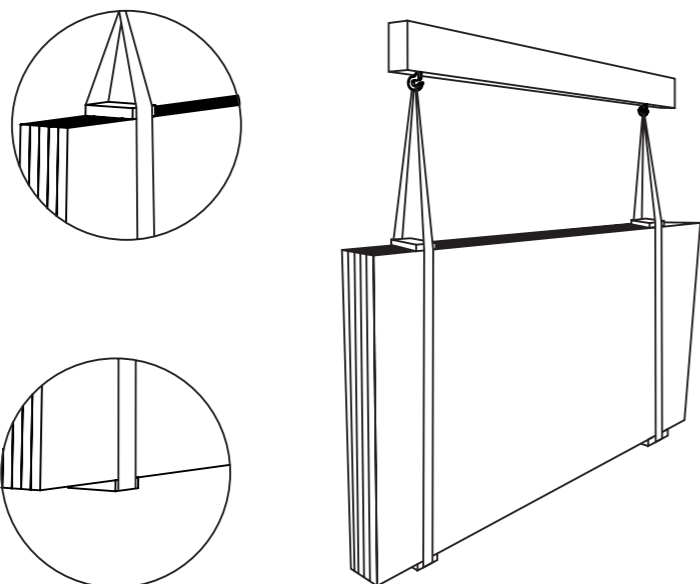

Manual transport

Always keep in mind the weight of anything that needs to be transported. Get help from any type of support and never move slabs in a flat horizontal position as this may cause excessive buckling.

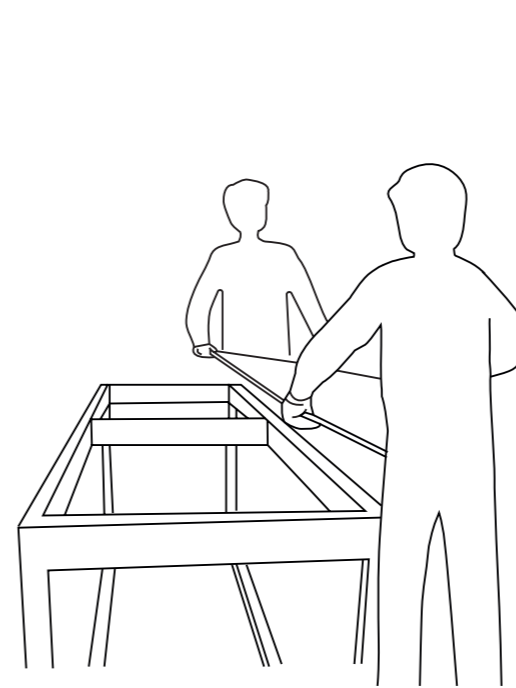

✗ INCORRECT

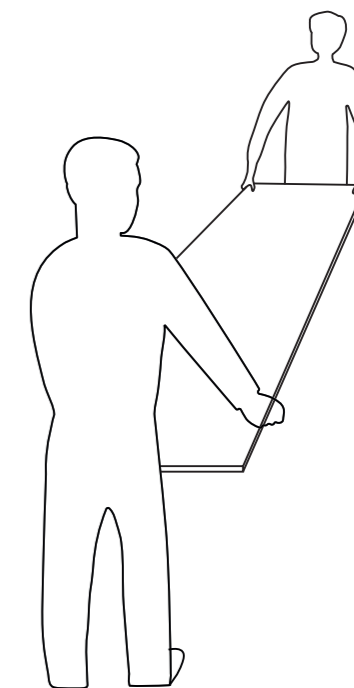

✗ INCORRECT

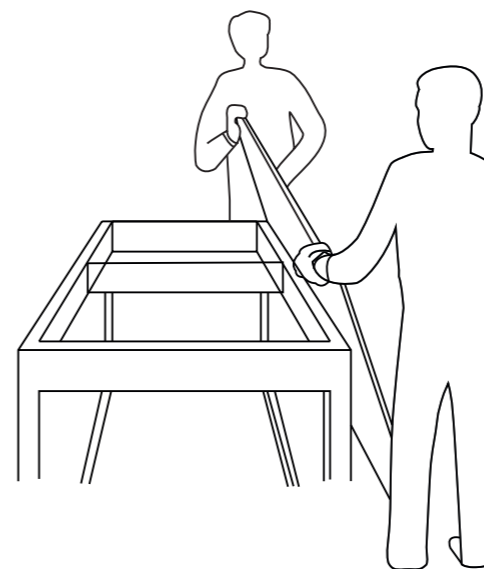

✓ CORRECT

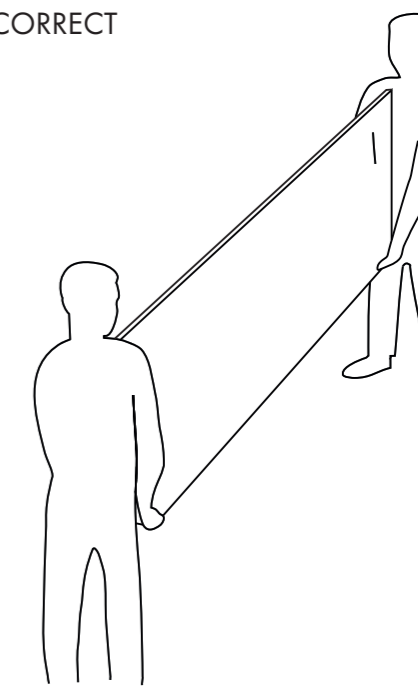

✓ CORRECT



Transport using a frame with suction cups

This is only recommended for 6 mm thick slabs. The suction cups can be positioned all along the frame to adapt to the size of the piece being moved. Using this tool is also recommended when installing the slab in its final location.

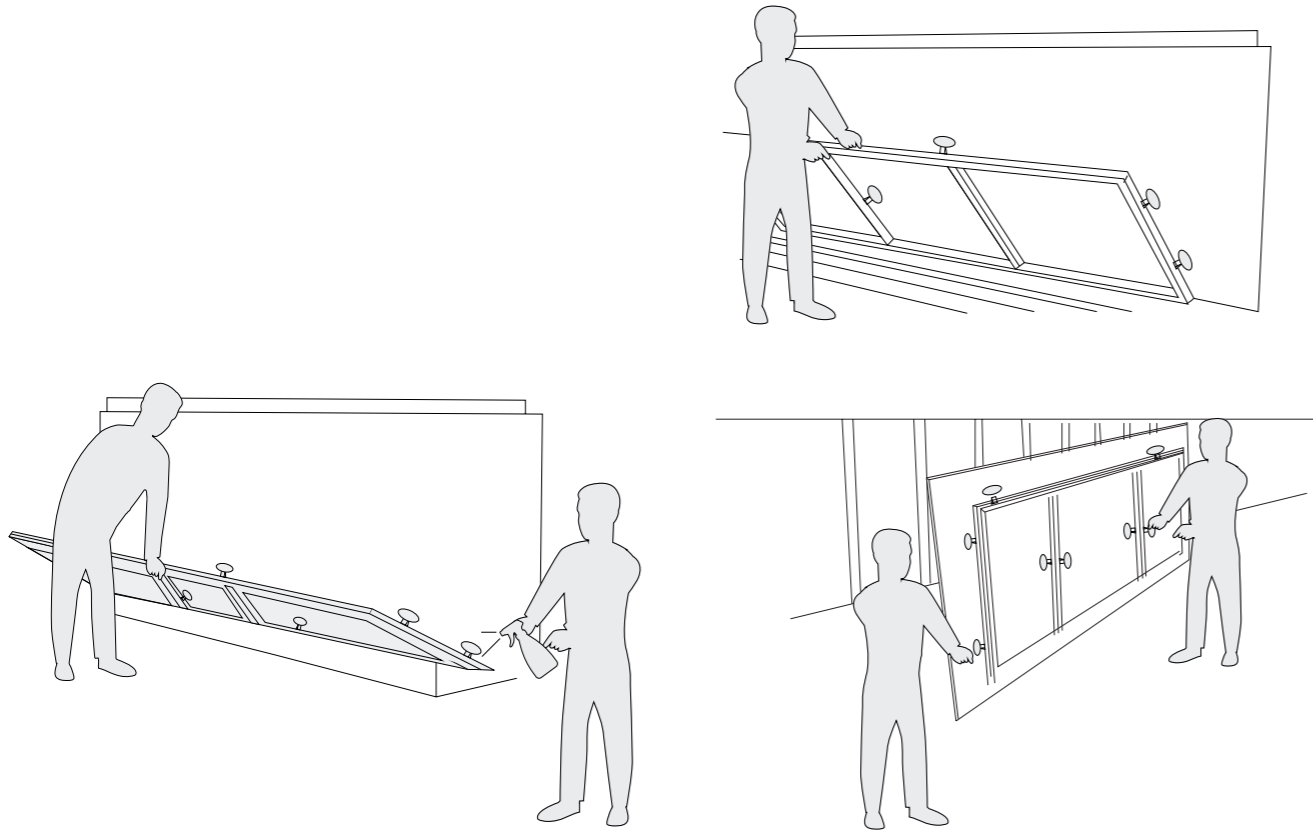

If this type of frame is not available, an aluminium rod or similar element, secured with several jacks, can also be used. This will prevent the piece from bending too much while being handled.

Fixing thin, long pieces (skirting, for example) with jacks to an aluminium rod for transport is also recommended.

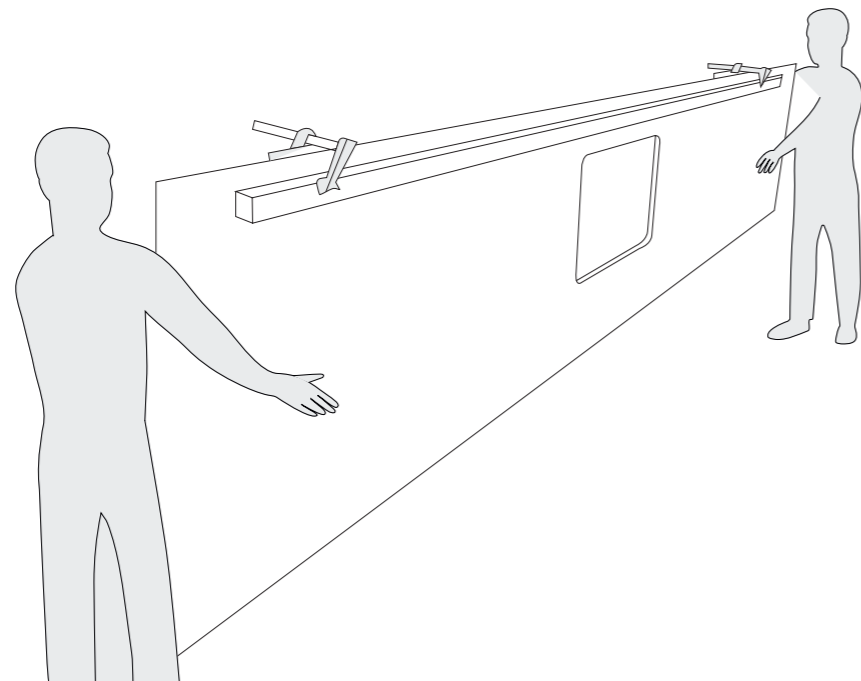

Packing

After production, the slabs are placed on trestles which are ideal for transport and storage after proper labelling.



Trestles with Ascale slabs should be loaded, unloaded and moved using a suitable forklift, crane or other handling mechanism.

Whenever handling or moving items, make sure the load is balanced.

If possible, keep your Ascale slabs on the same trestle they came on. Any subsequent handling must be by using adequate trestles or rails (wooden or metal) with proper protection to vertically support the slabs (wooden, plastic or rubber) to prevent chips and dents at the support point.



Storage

When storing slabs on trestles not supplied by us, using a continuous support base or at least one with four support points for the slabs is recommended. This base should be rigid (preferably made of wood). This will prevent splintering on the edges of the Ascale slabs.

Make sure the Ascale slabs have at least three support points (one in the middle and one at each end)

When storing outdoors, cover the slabs with waterproof fabric.

Cut pieces may have sharp edges, so handle with care and use adequate protection.

Cut material should be packaged with cardboard or similar protection on the corners and with shock absorbent panels around the perimeter edges (in adequate thicknesses) to protect against impact.

If the product is not packaged adequately, it may break.

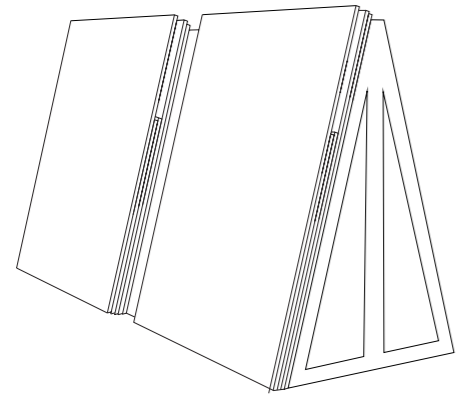
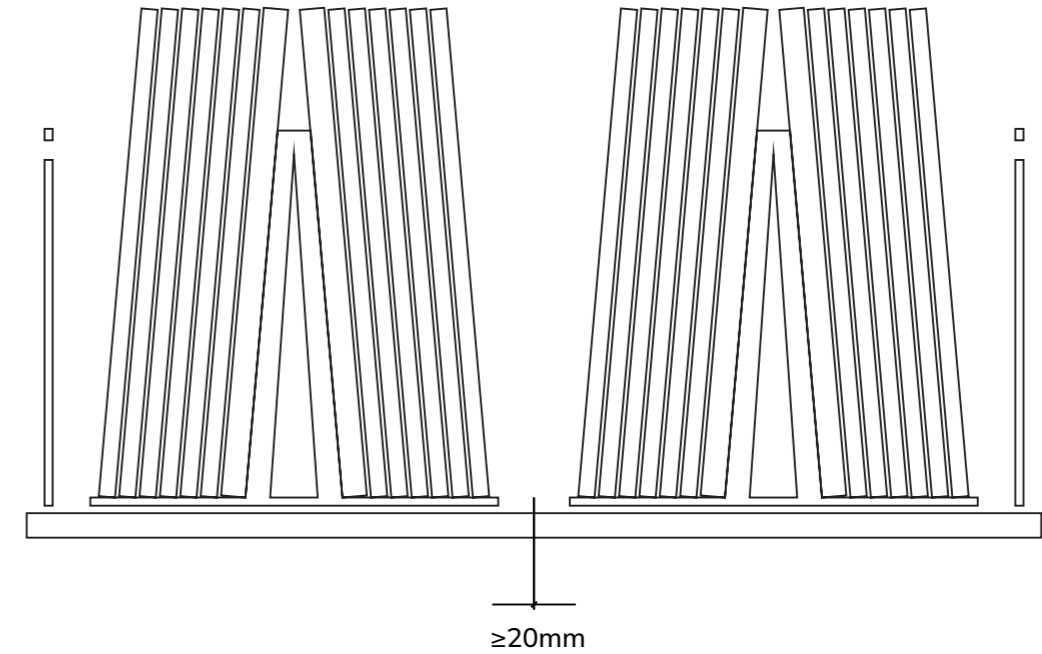

X INCORRECT

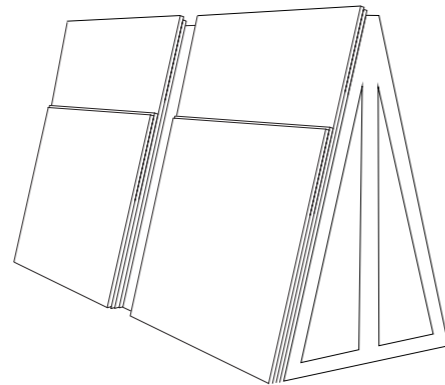

✓ CORRECT

“Avoid positioning large slabs against smaller slabs:”

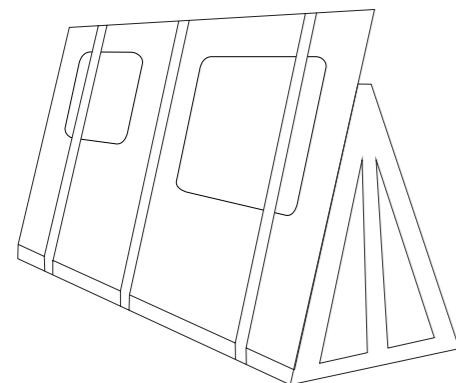

X INCORRECT

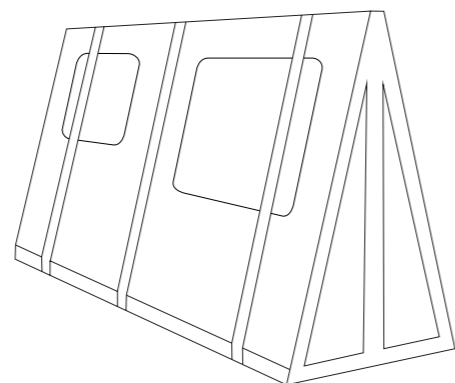

✓ CORRECT

“Likewise, check that the trestle or base on which the slabs are supported is larger than the slab surface:”





3. RECEPTION AND QUALITY CONTROLS

Ascale performs quality control on its slabs in accordance with the highest standards of quality. Nonetheless, always inspect received material before starting any work by following these steps:

- Check the packaging exterior (no visible impacts or damages).
- Check that the transport document, the purchase order and the material received all match. The product code is printed on the side edges of each slab.
- Visually inspect the slabs for possible surface defects: cracks, stains, colour fading, shade variation and imperfections. An inspection against the light is highly recommended.

No claims will be accepted for installed or manufactured material when defects were already present upon delivery of the material. Marble workers are responsible for determining whether the slabs are adequate for use. If they are not adequate, the supplier must be contacted immediately so they may be exchanged before the slabs are cut or modified in any way.

ASCALE 183 AS.ANTALYA SAND 160X320 MATE 20MM 100 MADE IN SPAIN 8429991903107 H01

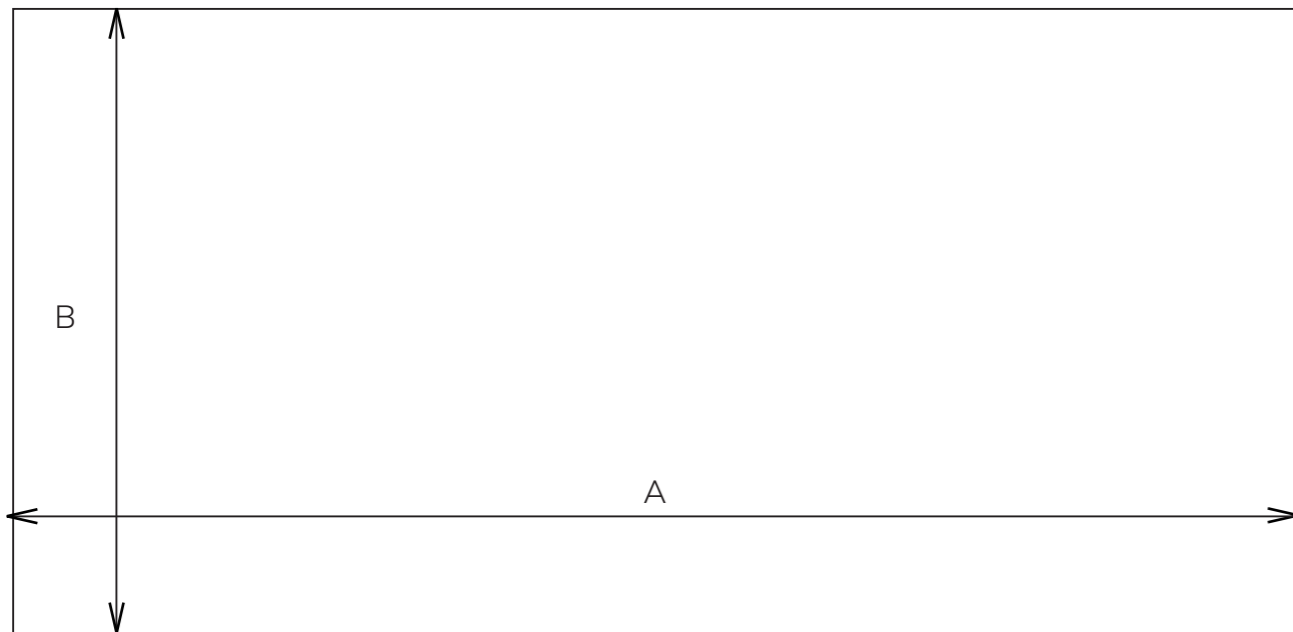

Dimensions	Length mm (A)	Width mm (B)
For guidance only	3240	1620
Useful for 6 mm	3197	1597
Useful for 12 mm	3240	1620
Useful for 20 mm	3240	1620

Flatness

To check the flatness of a slab, position it over a completely flat horizontal base free of any residue.

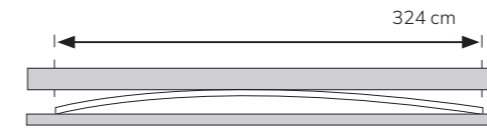

Maximum slab width and length tolerance: 2 mm

Any convex deviation from total flatness should be measured using an aluminium rod held parallel to one of the sides. The section of a slab showing a possible bend can be assessed using a 2 mm thickness measuring device. If the thickness measuring device does not fit underneath, there is no flatness problem.

Dimensions

The term "Full Size" means that the slab has undergone the production cycle without being cut down. This size is intended for processing because it provides manufacturers with the opportunity to optimise their possible cutting models to suit specific projects. A piece measuring 162x324 cm can be obtained from each slab, which corresponds to the useful surface and the billable amount.

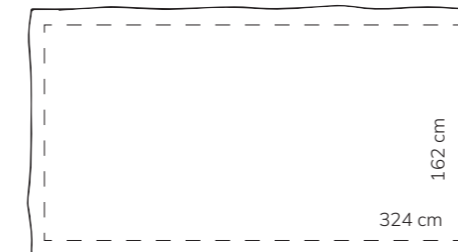

Slab identification

Each slab is affixed with a label indicating important information to ensure their traceability such as the model, tone and production date. Keep or record the label for future reference.





4. PARÁMETROS DE MECANIZACIÓN

Preliminary information

Before working with the slabs, always make sure the entire slab is supported on the bench and the bench is free of any shards. The slab must be completely flat.

To release any strain on the raw slab before handling, we recommend correcting the edges by cutting approximately 2 cm from each side.

Recommended sequence for strain release cutting:



Due to the hardness of Ascale material, the disc cutter should be suitably cooled. The cooling jet must be continuous and always target the cutting point where the disc cutter will be in contact with the slab:

Sink holes: before making the cutouts, you should drill the corners of the holes using a bit with a radius of at least 5 mm.

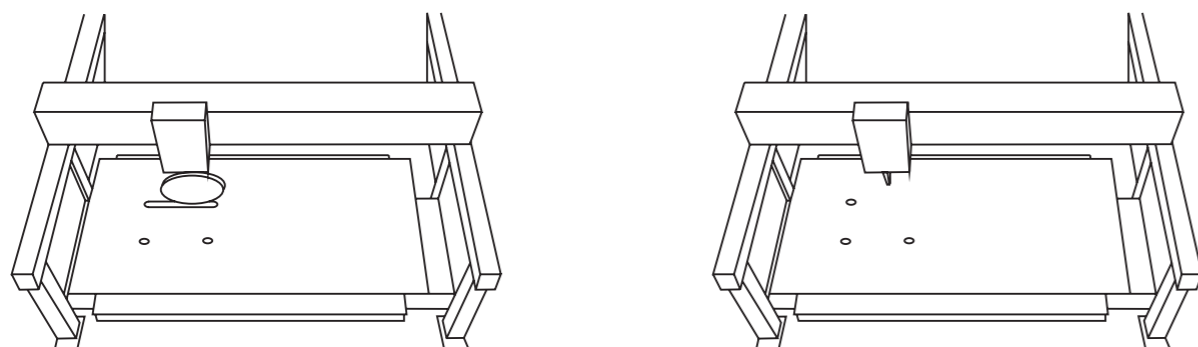

4.1 Cutting with a Disc Cutter

We recommend cutting Ascale slabs with a segmented disc cutter. The cutting parameters are as follows:

Disc	RPM	Forward speed (m/min) for 6/12/20 mm thicknesses	
		Straight cut	45° cut
300 mm	As per the manufacturer	3/2,5/2	1,5/1/0,7
350 mm		3/2,5/2	1,5/1/0,7
400 mm		3/2,5/2	1,5/1/0,7

These speeds should be reduced by 50% at the beginning and end of the cut (approximately 15-20 cm at the start and end of the cut):

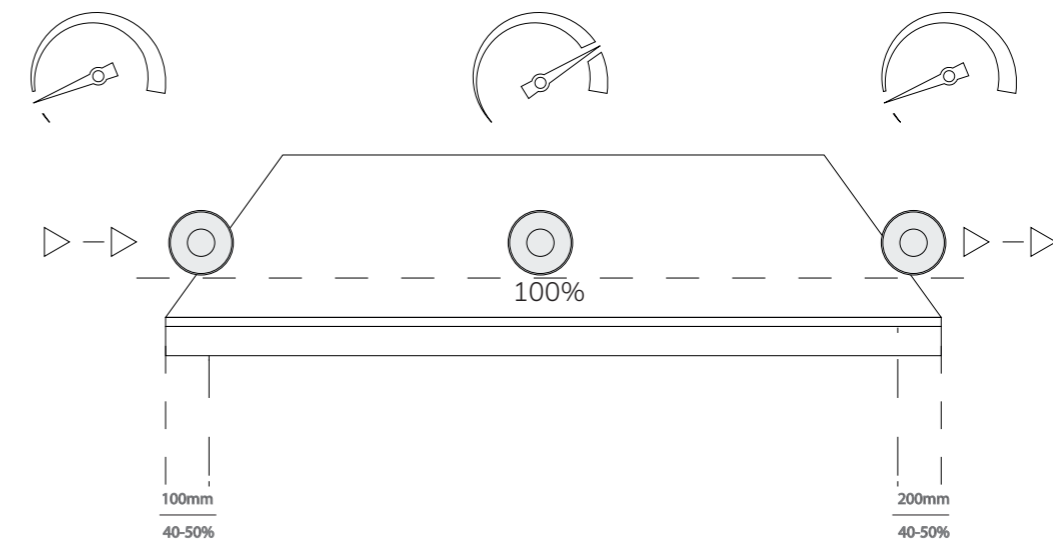



4.2 Parameters for CNC Tools

Ascale slabs can be cut using computer numerical control (CNC) machines.

The most complex CNC machines offer the option to rotate and tilt the cutting head for numerous types of cuts. CNC is normally used after shaping the upper part with a disc cutter or hydrojet.

These machines are mainly used to cut out sink holes and for finishing off the edges of flush countertops, holes, edges and curved lines. The tool must have a diamond tip to process porcelain tile. Your choice of machine will depend on the specific process to be performed.

Do not make cuts or holes while the machine is oscillating. It is important to use plenty of water aimed in the right direction while cutting, both inside and outside of the machine.



The machine must be at least 1 mm wider than the thickness of the slab.

Tool	RPM	Forward (mm/min)
19-22 mm cutter	4500-5500	150-250
35 mm drill bit	3500-4000	10
Router bit	6000-9000	400

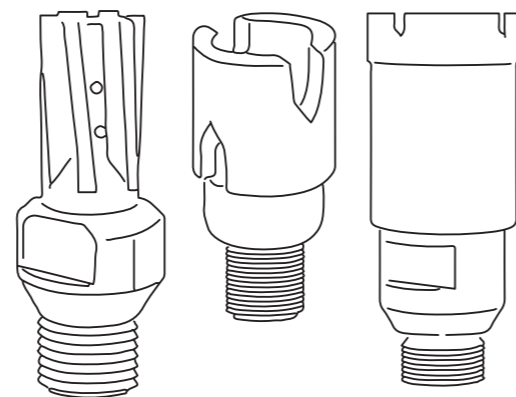

Positioning suction cups

Before starting the process, check that the suction cups are correctly positioned on the rear of the slab.

If anchorage is insufficient, use softer joints of a suitable thickness.

Correct placement of the suction cups holding the slab is fundamental to obtaining a good cut. Suction cups should therefore be spread evenly so as to hold the slab, including any part(s) to be removed. If this is not done, the part of the portion already cut could bend and lead to cracking before the process is concluded.

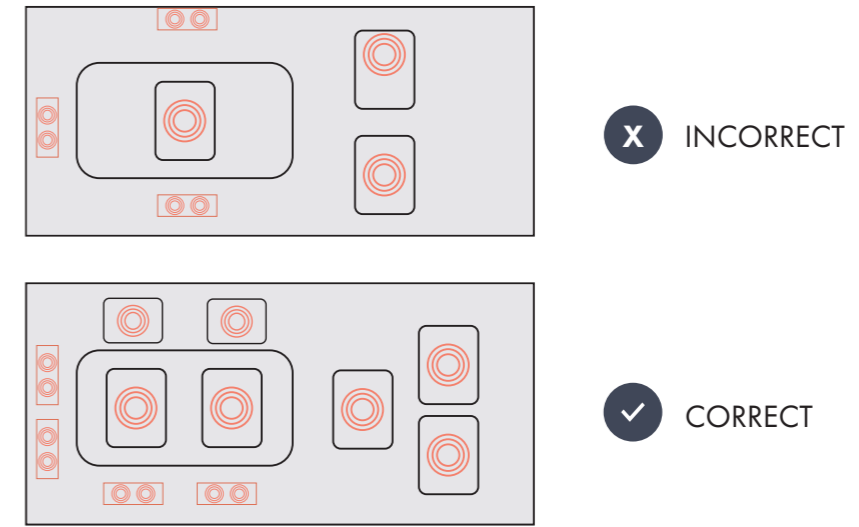

Clamps can be used instead of suction cups, in which case it should be remembered that the clamp side cannot be cut.

Cutout cutting diagram

Make cuts as shown in the diagram below, without cutting into the hole perimeter at 90°, as this will compromise quality in the final process.





Flush process

We recommend concluding the countertop flush process before proceeding to cut.

A maximum rabbet of 4 mm can be cut in a 12+ Ascale slab and 8 mm in a 20+ Ascale slab, with suitable sizes and depths based on the instructions contained in the technical data sheet for the sink or apparatus to be installed.

Cutting parameters

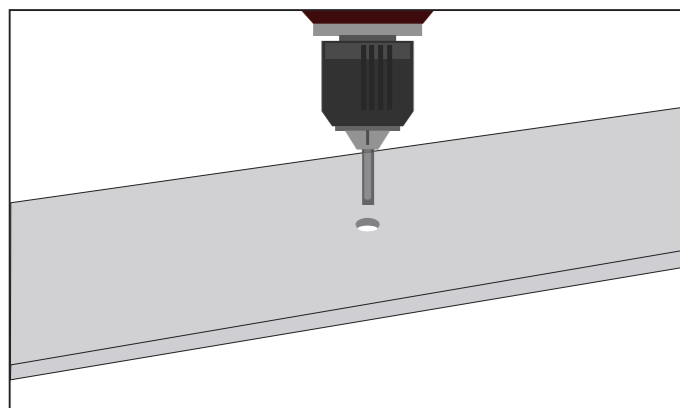

Drilling

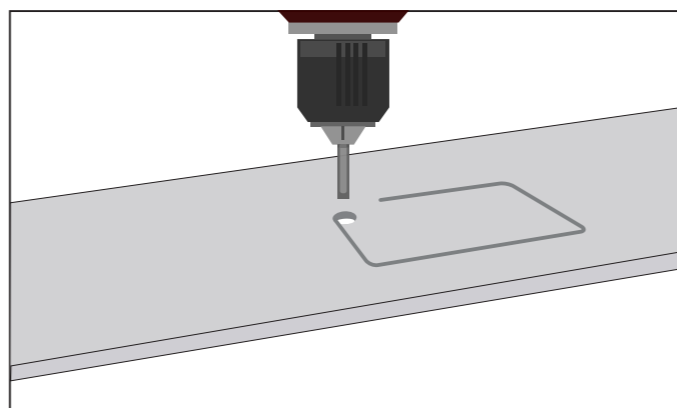

Edging

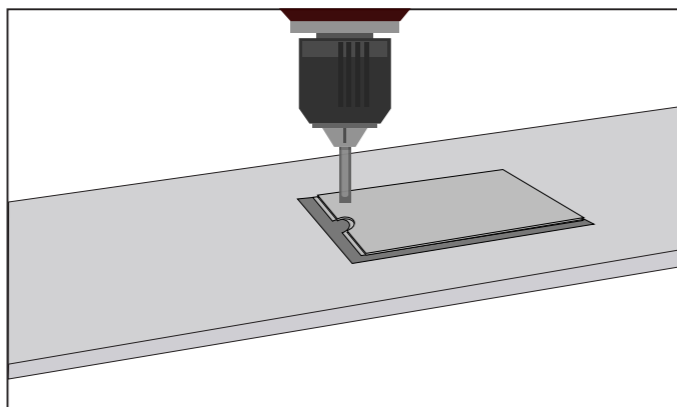

Cutting

4.3 Manual processing

A manual cutting tool can be used to cut 12+ and 20+ Ascale slabs.

By using such accessories as cutting discs, diamond bits or abrasive pads of various grades, it is possible to obtain cuts, holes or finishes for edges or details on the surface of countertops.

The slab being processed should be suitably positioned to prevent movement and vibration. The area being processed and the tool being used should be constantly bathed in water to ensure proper cooling and process quality.

Post-processing Cleaning

Cutting, drilling and similar operations lead to dust residue caused by material abrasion. This residue tends to solidify on the surface once the water needed during the processing stage dries.

Correct cleaning is therefore essential after the processing stages because if this is done incorrectly it can produce marks that are difficult to remove (especially visible on darker colours).

Clean processing residue from the slab surface with plenty of water and then dry it with a paper cloth. Repeat this operation until it is clean. Avoid storing processed material that is still wet.

Polyurethane or epoxy adhesives are used when assembling the countertop and creating the edges, suspended sinks, etc. Epoxy products have been designed not to unstick, thereby guaranteeing long-term performance. For this reason, they could stick to the surfaces without being absorbed and make removal difficult or even impossible.

It is therefore essential to remove them quickly using sponges or soft cloths and the cleaning products recommended by the suppliers. Avoid contaminating the rest of the surface with cloths/sponges used to remove this material. Do not move the finished surface wearing gloves that are dirty with adhesive products.

If any epoxy/polyurethane material is observed after installing the countertop, it will need to be treated with basic products and soft sponges. However, it may not always be possible to completely remove this material as it will have completely dried.

4.4 Waterjet Parameters

The entire surface of the slab must be supported on the ribs of the waterjet. The ribs must be as close as possible and must be in perfect conditions.

For perimeter and outer cuts, first discharge water off the slab. Then, make the first hole in the slab at 700 bar pressure for 10 seconds. After that, increase the pressure to around 3900 bar to begin cutting.

If the machine software and design allow, finishing the cut as close as possible to the edge of the slab is recommended.

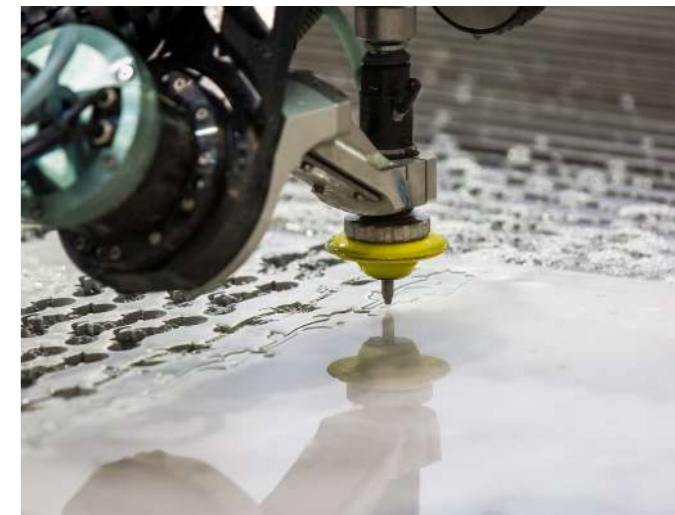

Other recommended parameters:

Head	0,88 mm
Abrasive flow rate	500 gr/min
Cutting speed (6 mm+)	1,8-2,4 m/min
Cutting speed (12 mm+)	1,2-1,8 m/min
Cutting speed (20 mm+)	0,6-1 m/min



5. RECOMENDACIÓN DE DISEÑO DE ENCIMERAS

5.1 Design and Shapes

Certain recommendations should be followed when designing a countertop. Here are a few cutting, design and architecture tips to help reduce problems caused by breakage, cracks or deformations in the final product.

Ascale recommends using 12 mm and 20 mm thick material when producing countertops.

If the countertop design allows, avoid Ascale countertops with unbalanced weights:

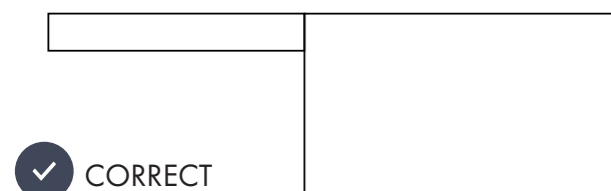

Irregular cuts are also not recommended such as for a “farmhouse sink”. In these cases, add joints to the countertop design:

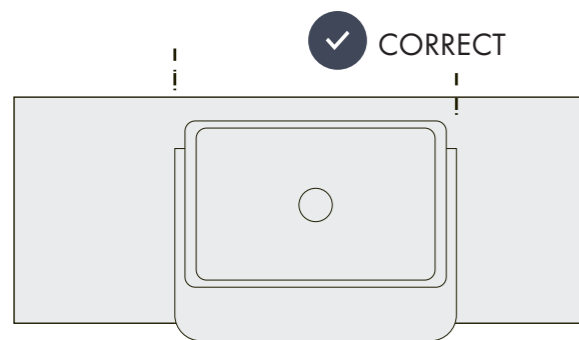
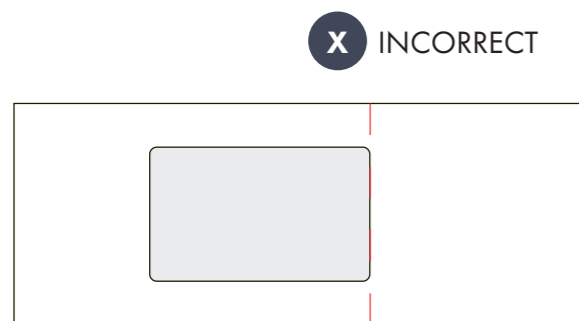

5.2 Planning

Consideraciones generales

To the extent possible, the following indications must be observed:

- Make sure the support is in the final position
- Measure and project the size, shape and location of the surface. Measuring precision is essential for proper production and installation.
- Plan production with rectangular pieces that are as big as possible with the least amount of slab waste.
- Pre-mark the furniture with the location of any joints to be placed on the countertop. Joints should be placed on complex seams. Check that the surface is even in the places where joints will be added.
- Check the location and available space for any accessories to be placed in the countertop considering the distance between them and the areas around them.
- Do not cut visible edges on the countertop in accordance with slab edges given that the raw slab edge is not appropriate as a final slab edge.
- Si el proyecto incluye el uso de varias tablas, verifique la orientación de la gráfica del material.

Gráficas

If the project includes the use of several slabs, check the graphic orientation of the material.

If several slabs are to be used for graphic continuity (bookmatch effect, for example), pay attention when cutting the pieces that will be joined together. As occurs with natural stone, this type of work may show slight isolated deviations in the graphics even when done properly. Ascale will not accept claims for this reason.

5.3 Joints

An empty space of at least 3 mm between the product and the supporting wall and approximately 1 mm between juxtaposed slabs must be planned during the work as expansion joints.

Due to the nature of Ascale slabs, micro-bevelling is recommended for all joints.

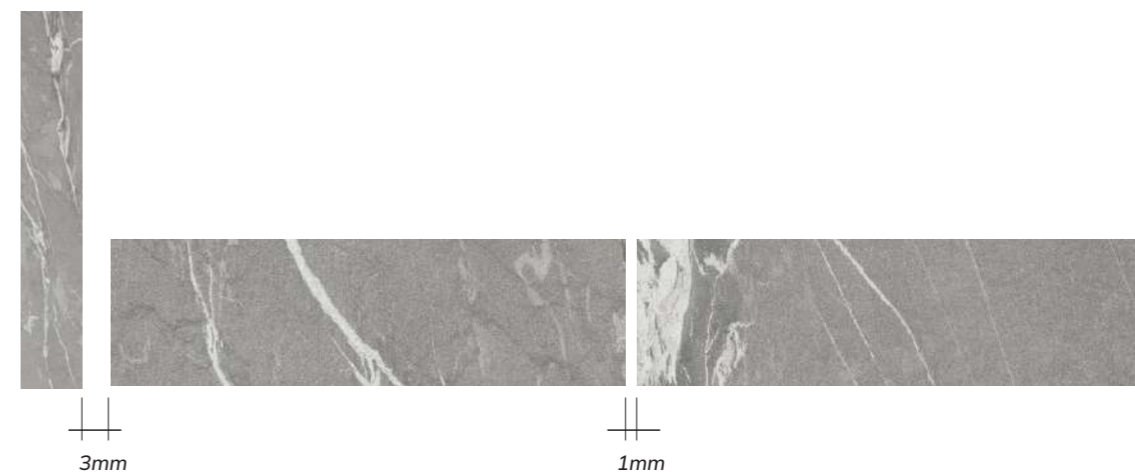



5.4 Designing Holes for Sinks and Hobs

The minimum distance allowed between holes or cutouts and/or from the edge of the slab is 5 cm. If a gas hob is being used, leave 8 cm between the hob cutout and the backsplash.

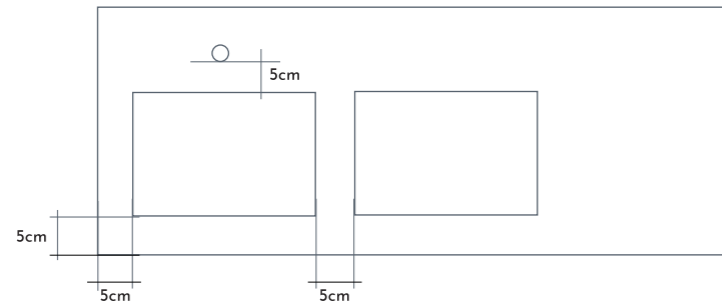

The inner angles of the cutouts must have a constant radius of 5 mm.

If cutting with a grinder, drill holes must be made in each of the corners with a 10 mm drill bit prior to the cuts on the straight sides.



X INCORRECT

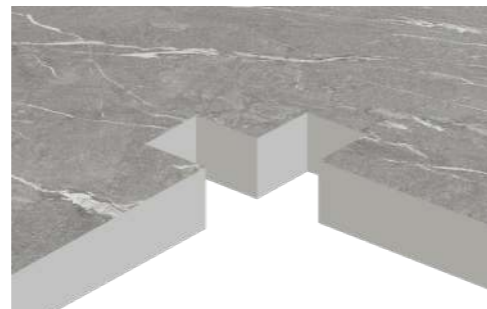

X INCORRECT

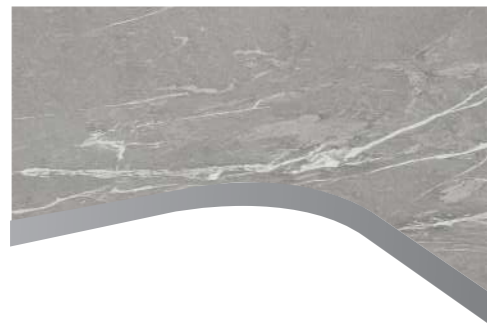

X INCORRECT

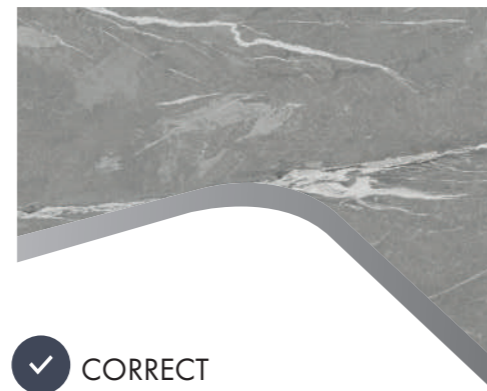

✓ CORRECT

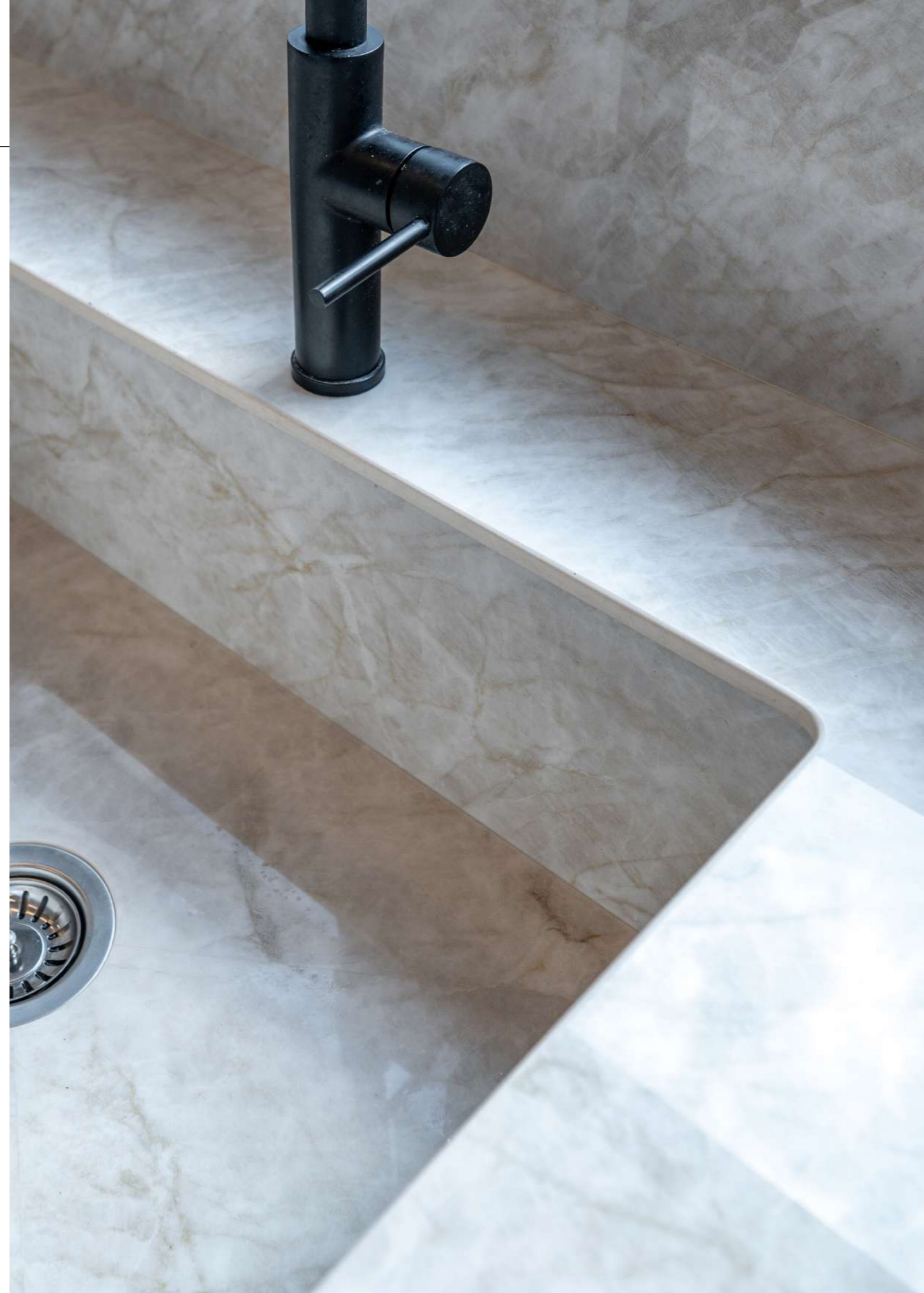



After cutting, the edges of the cutouts for vitroceramic hobs, sockets or switches are often a bit sharp or irregular; therefore, bevelling them with special diamond or abrasive sanders is recommended.

Polishing the edges of the cutout is recommended to eliminate any microcracks created when cutting. The more intense this treatment is, the less risk there will be in the future.

If large-size cutouts are planned (more than 70 cm), place a pre-cut bar approximately 5 cm wide in the centre of the opening in the direction of the depth (which must be removed after installation) to make any movement in the piece less critical.

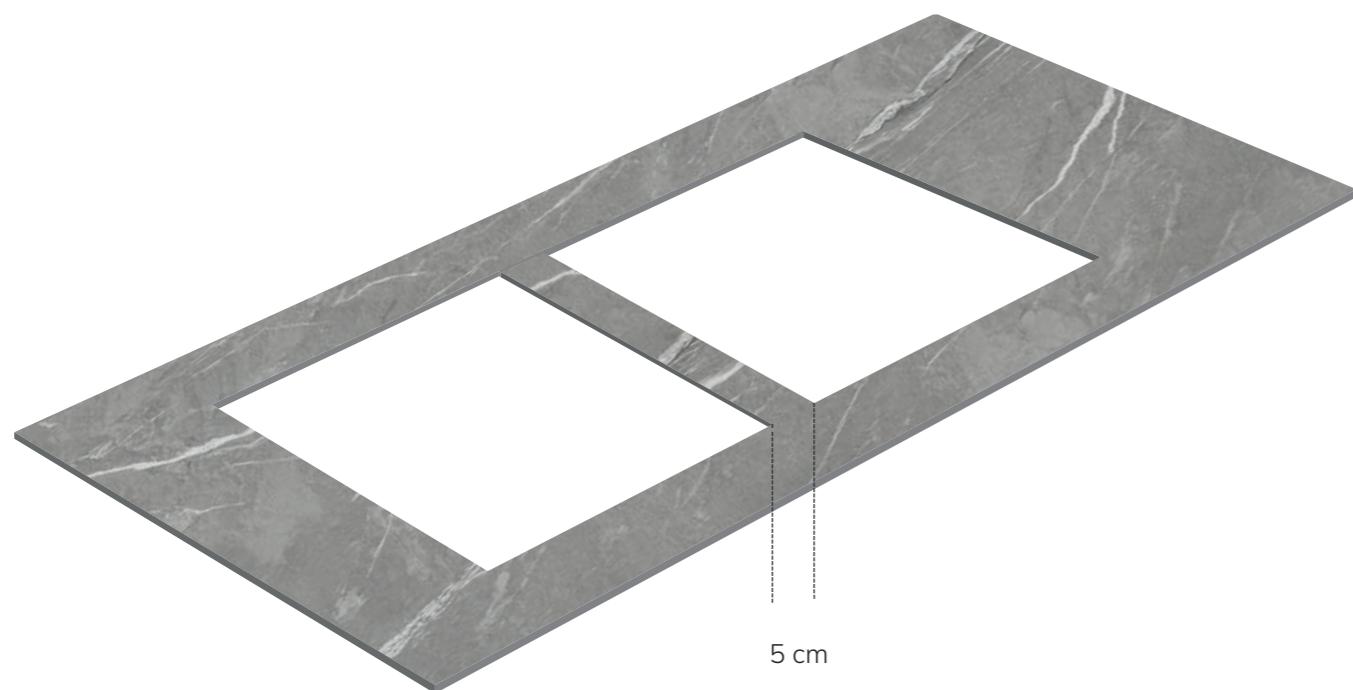

Kitchen hob over the countertop

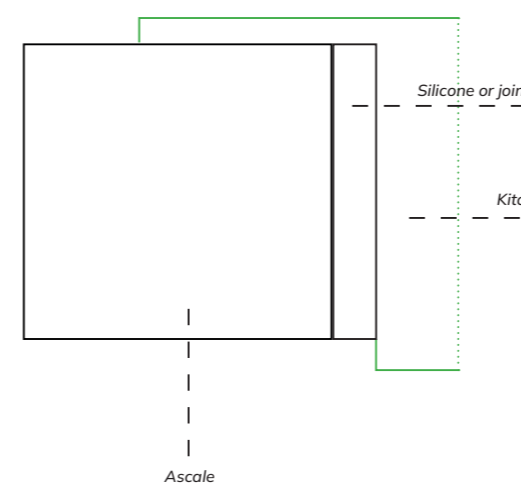

Kitchen hob flush with the countertop

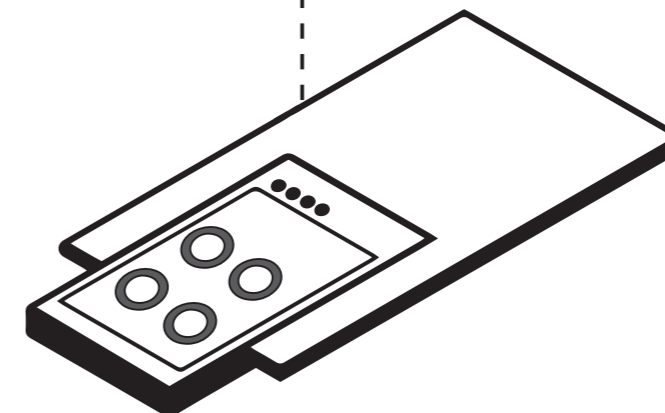
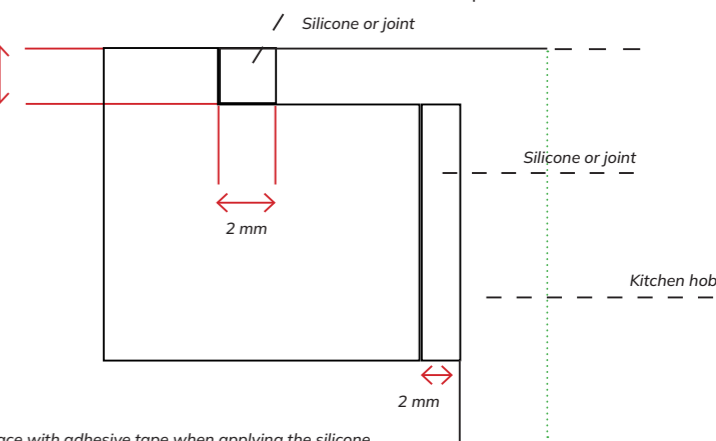

Processing Ascale 12+ and 20+ slabs to create holes for installing sinks or electrical appliances should only be done after a careful assessment of the processing measurements indicated in the data file for the product to be installed based on the installation method.

A minimum distance of at least 2 mm is required between the kitchen hob and the Ascale slab for the purpose of thermal dilation unless the device manufacturer indicates a larger distance. The gap should be filled with a suitable sealant.

Regardless of the type of sink being used in the project, support bars or other similar systems should be anchored to the unit structure to support the weight of the sink and the water it may contain so that it does not depend on the slab.

Regardless of the type of sink being used in the project, support bars or other similar systems should be anchored to the unit structure to support the weight of the sink and the water it may contain so that it does not depend on the slab.

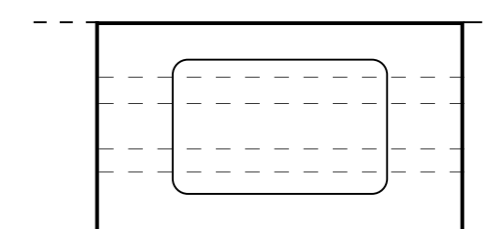
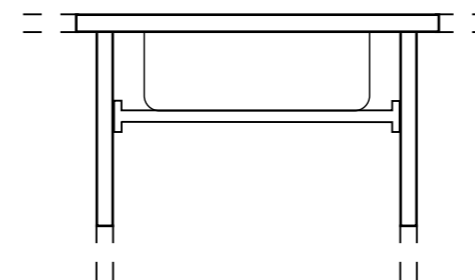



If the base has sliding drawers, these supports should have the proper shape so they can slide correctly:

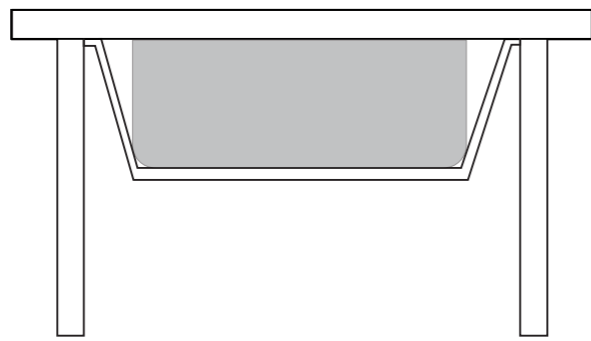

Depending on the project (such as repeated grooves in close proximity), assess the possible need to reinforce the cut-out perimeter by applying an Ascale profile with a suitable adhesive underneath the countertop.

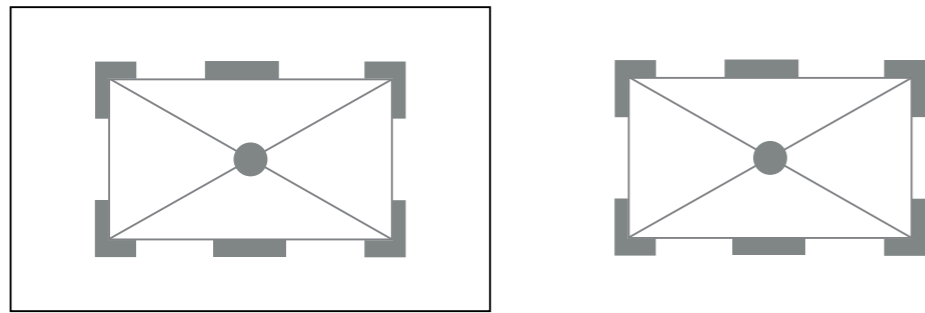

The Ascale 12+ and Ascale 20+ slabs can be processed to obtain different configurations for sinks and kitchen hobs.

Inside corners

To create inside open corners, make an adjustment based on a minimum radius equal to 5 mm in order to distribute tension in the same way you would normally when processing natural stone, marble and compound stone.

We do not advise creating right-angle inside corners (90°).

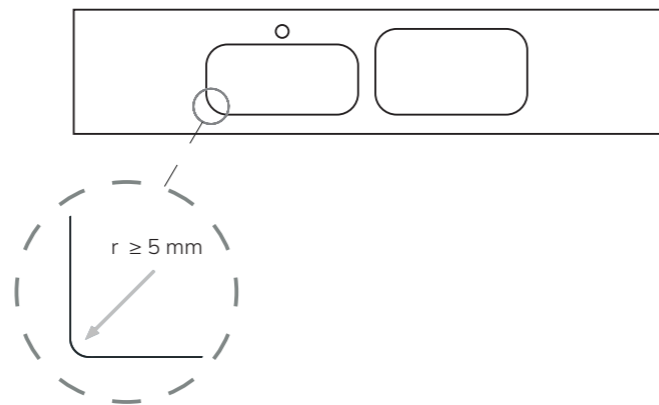

As for all stiff materials like marble, natural stone, quartz agglomerate and glass, it can be done under operator liability based on their own personal experience and using processes that the operator has tested and considers suitable.

5.5 Sinks and Hobs

Undermount sinks

To reduce the risk of splintering at the edges to a minimum, a round edge or even a corner cove edge with a radius of at least 3 mm is recommended.

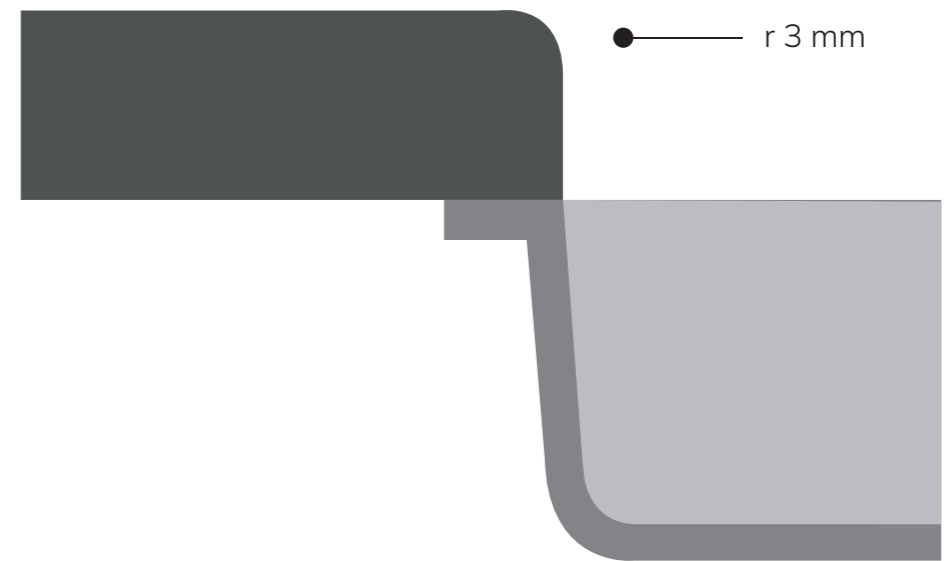



Flush sinks and hobs

Flush sinks and induction or vitroceramic hobs supported on rabbets made on the surface of the countertop are only recommended for 12 mm and 20 mm thick countertops with the following maximum rabbet depths:

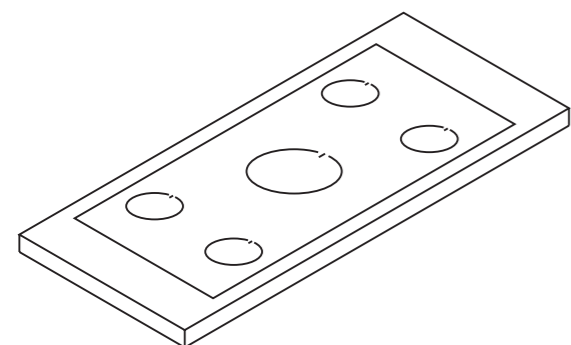

Slab thickness	Maximum rabbet depth
12mm	5mm
20mm	8mm

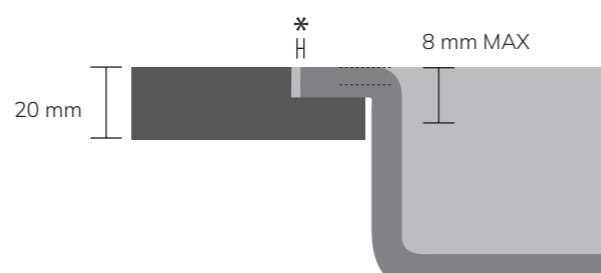
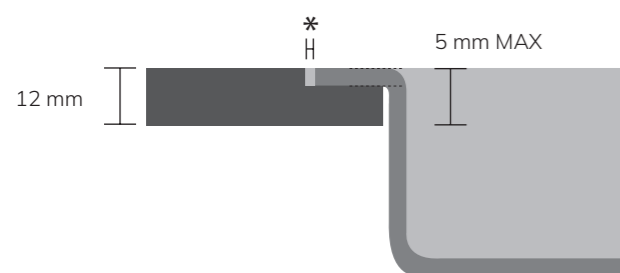

For large-size sinks, you might need to place a supporting rod under the sink:

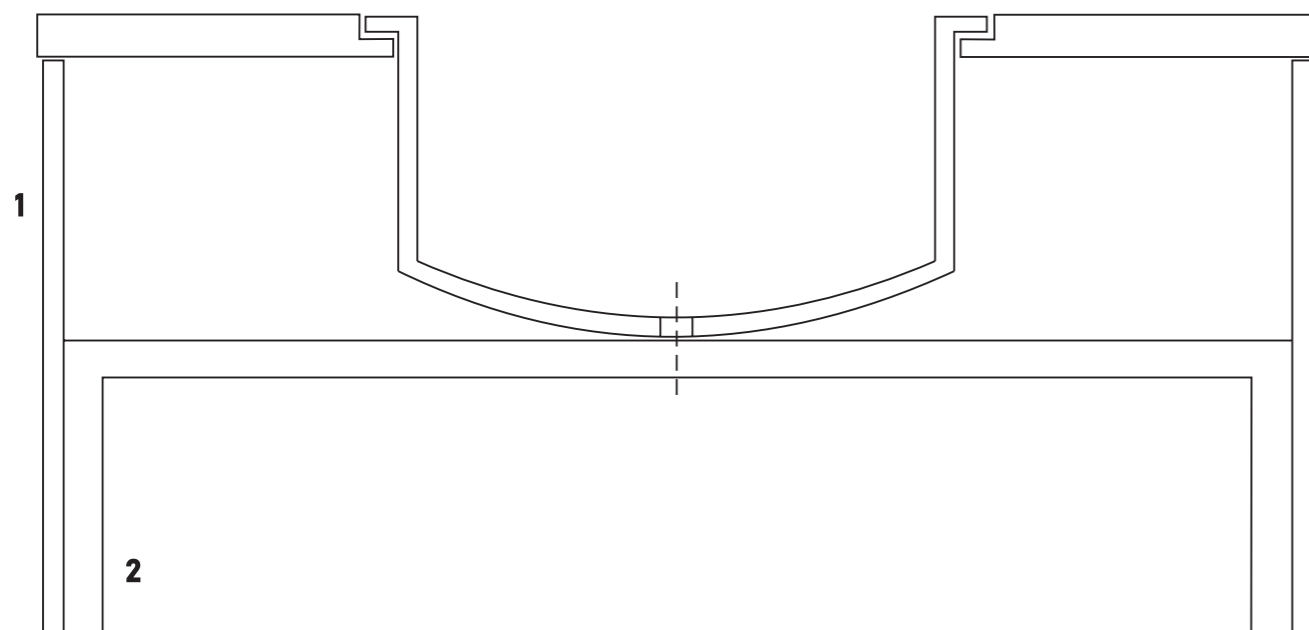

Draining grooves

The best result for this work is achieved in full body materials where the finish on the grooves looks just like the normal slab surface. Considerations for this type of work:

- Procedure: create the rabbet based on the instructions provided in the section of this manual entitled "Cutting Parameters and Recommendations", starting from the hole for the sink. Sand the grooves by hand to remove any marks left by the router bit. Finally, treat the grooves with a sealant to prevent water absorption in that area.
- The depth of the channels must be limited to 25% of the thickness: 3 mm for 12 mm and 5 mm for 20 mm.
- The minimum distance between grooves should be 1 cm.
- Furthermore, the grooved area will need additional reinforcement on the back of the slab.

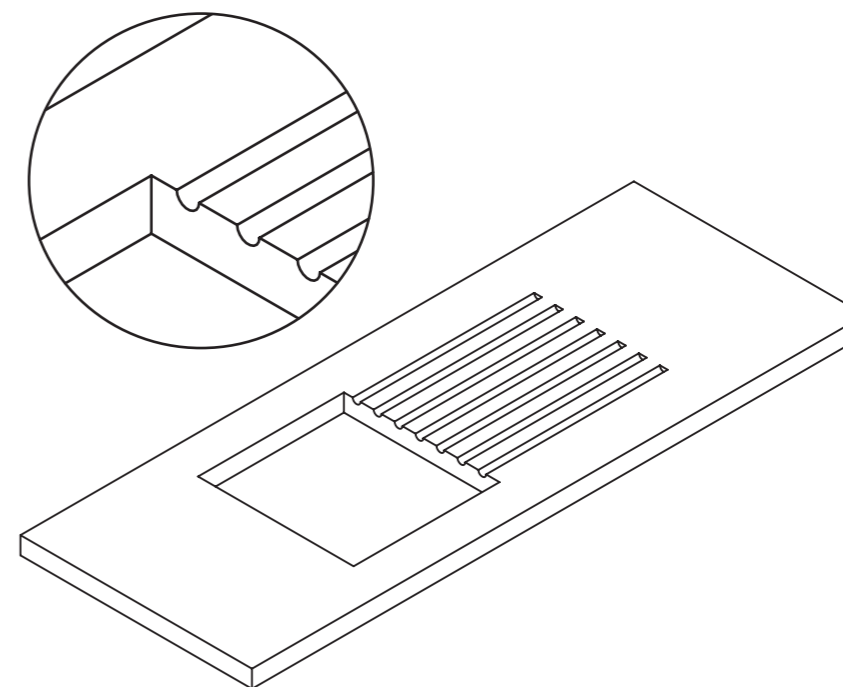

Se debe tener en cuenta que al hacer las hendiduras se mostrará el color base de la tabla, que puede contrastar con el diseño de la superficie en algunos modelos. Según el modelo, las hendiduras pueden cambiar de color y quedar sin diseño.

Fabricación

Rebaje

Utilizar fresolín de rebaje y comenzad siempre desde el hueco del fregadero. Nunca bajar el fresolín directamente sobre la superficie.

Durante las dos primeras pasadas, eliminar 0,5 mm; después, se pueden quitar un máximo de 2 mm por pasada.



5.6 Edges

Edge finishes can be obtained by processing with automatic machinery (polishers, numerical control machines) or by hand, depending on the desired effect.

Straight and bevelled edges

The straight edge is the finish that enables the edge of Ascale 12+ and Ascale 20+ slabs to be shown. This is usually used for the perimeter edge of the surface of countertops and kitchen panels, or as the finish for a hole when installing the sink beneath the countertop.

If required, the edge can be polished subsequently using a sequence of increasingly finer abrasive diamond grinders on CNC machines. We suggest creating a bevelled edge of at least 2 mm to increase edge strength in the event of accidental impact. For curved bevelling, a CNC machine with a grinder on 5 axes will be necessary.

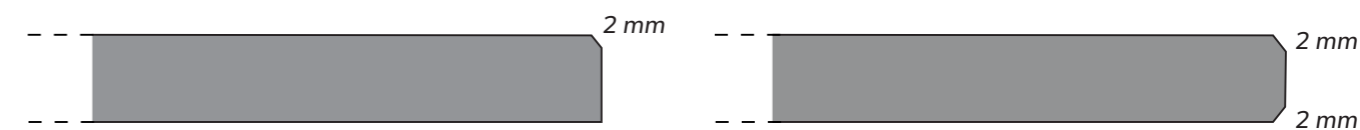

Other edge types

Other edge types can be obtained (such as the bull's nose and half bull's nose) using angle grinders with specific profiles on CNC machines. As a result, several different edge finishes can be obtained using different angle grinders. The working speed should be checked as a precaution.

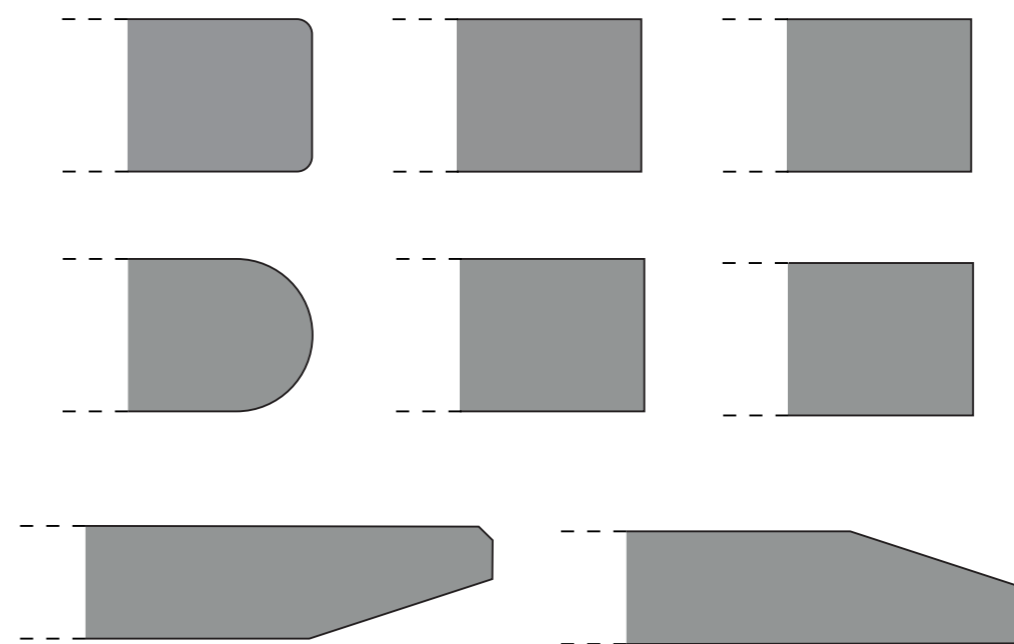

Available for the Bodytech range



45° edge and structures

Ascale 12+ and Ascale 20+ slabs can be processed to obtain continuous joints, which can then be used to create slabs of heights greater than the product thickness, sinks and other structures. This solution is also adopted when graphical continuity is desired on the front countertop panel.

After creating the pieces to be used, we recommend protecting the adjacent surfaces with plastic film or adhesive tape to prevent the slab being stained with glue because the adhesives will be difficult to remove once dry.

Clean the sections to be glued and apply an even layer of the adhesive over the entire surface. Make sure that the sections remain in position until the glue has completely dried, following the manufacturer's instructions. Once the glue has completely hardened, create a bevel of at least 2 mm.

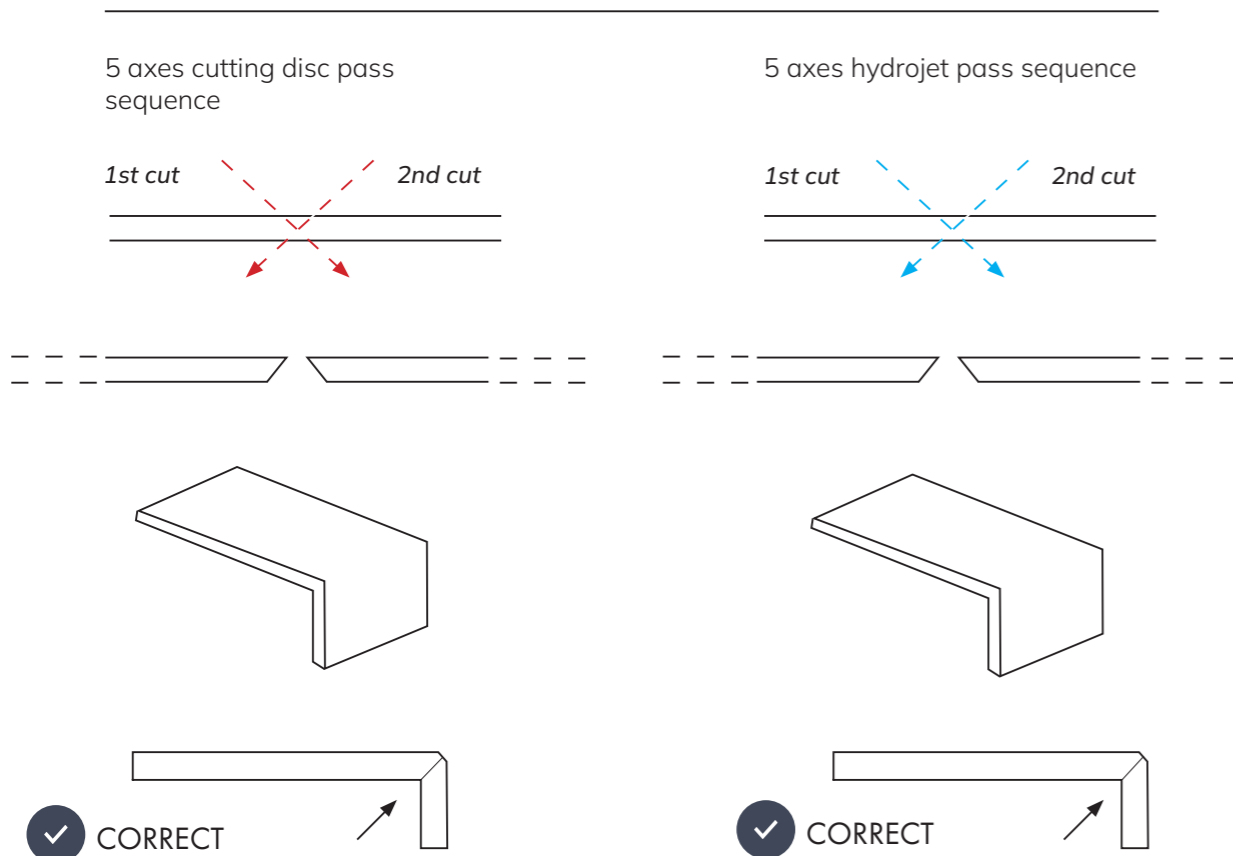

We suggest reinforcing the joint by applying profiles made from unused parts of the Ascale slabs secured with the same type of adhesive as that used to glue the 45° angle.

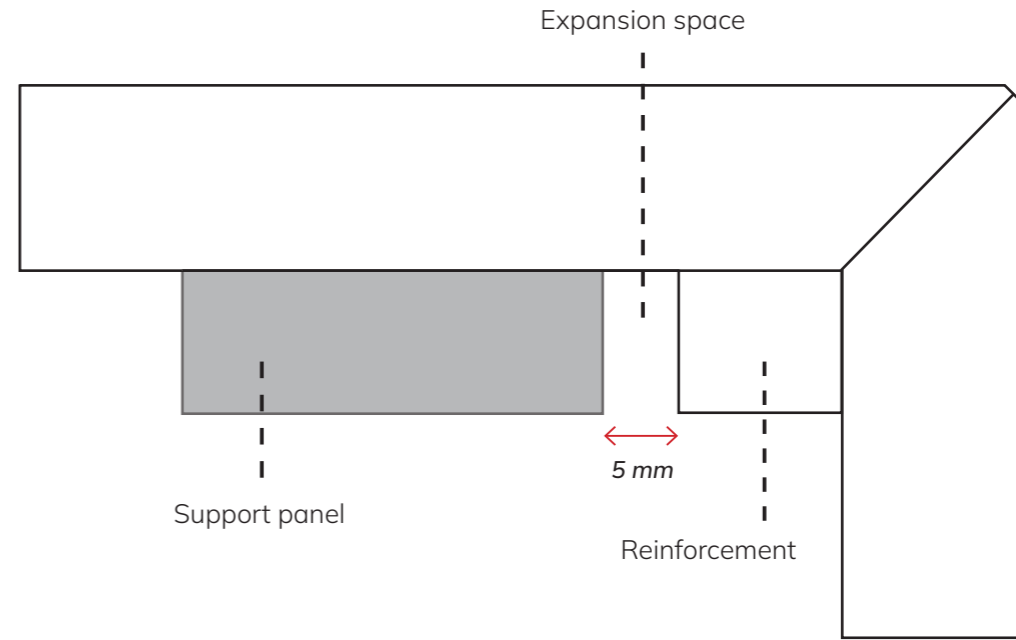

We recommend using two-component adhesives (generally epoxy-based or equivalent), which are widely available in the market.

These adhesives can be pre-coloured or transparent, and specific colour additives can also be used with them. A selection of products available in the market is shown below. Several companies have coloured glue or adhesive products in their range that can be combined with Ascale finishes.

Ask the manufacturer directly about suitable products.

We recommend proper and immediate cleaning of all glues and adhesives used, based on the manufacturer's instructions. Removing any glue later that has dried might be impossible and would lead to the formation of halos on the slab.

Bodytech finish for the edges

For finishing Ascale products produced using Bodytech technology, the surface structure can be recreated on the slab edges.

This is usually done using a sand blaster (commonly used for natural stone) with a suitable air pressure level and quantity of sand.

We recommend protecting the horizontal surface of the slab so it is not affected by the sand blasting process, which would compromise its finish and technical characteristics.

Fibre abrasion

The fibre reinforcement in the visible part of the countertop edge can be removed, either manually or using cutters, to improve the appearance. Because this is a fibreglass material applied with a polyurethane adhesive, this process should be carried out in accordance with applicable national safety regulations.



5.7 Substructure and Installation

12 mm and 20 mm (with reinforcement mesh) thick Ascale slabs do not require adhesive on a continuous structural support even though it is common practice.

The support material must be rigid, dimensionally stable for the conditions of use and have a thermal expansion coefficient that is similar to the slab. For outdoor countertops, do not use wooden supports or any recycled materials or materials with a thermal expansion coefficient that is too different from that of the ceramic material (6-7 M°K-1).

The countertop surface must be perfectly supported as any unsupported point may weaken the piece produced. Therefore, never apply isolated drops of silicone but rather extend the adhesive all across the supporting area.

12 mm thick slabs must be fixed to a base (total perimeter of the perfectly aligned furniture or substructure) in a 600 x 600 mm square.

20 mm thick slabs must be fixed to a base (total perimeter of the perfectly aligned furniture or substructure) in a 900 x 900 mm square.

Continuous surface reinforcements such as an integrated board on the furniture should be placed on countertops with straight edge designs where the substructures cannot be hidden.

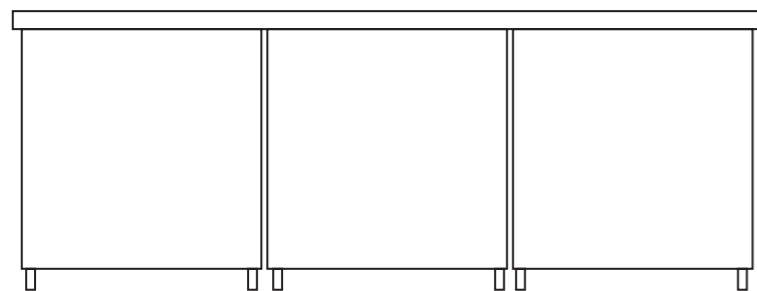

✓ CORRECT

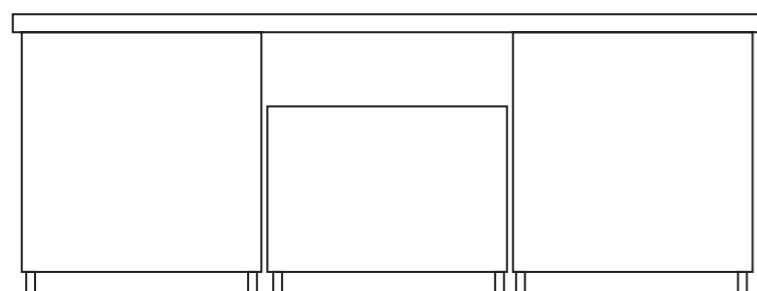

✗ INCORRECT

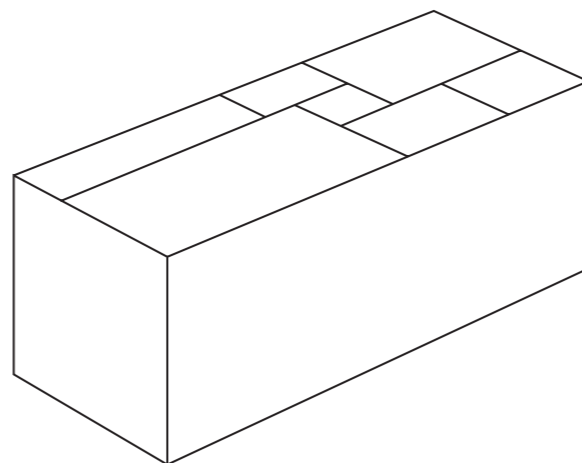

5.8 Reinforcements

These reinforcements are important because they give the countertop more rigidity and stability. The reinforcements must be distributed all along the perimeter so they are directly supported on the sides of the kitchen furniture. For tap holes, wooden or similar reinforcement is recommended as it will distribute the tension generated during daily use.

For countertops with 45° edges, the edge reinforcements must be made with the remains of the slab used or dense granite. Do not use reinforcements made of other materials (quartz, for example) as the thermal expansion may cause curling or openings in the edging.

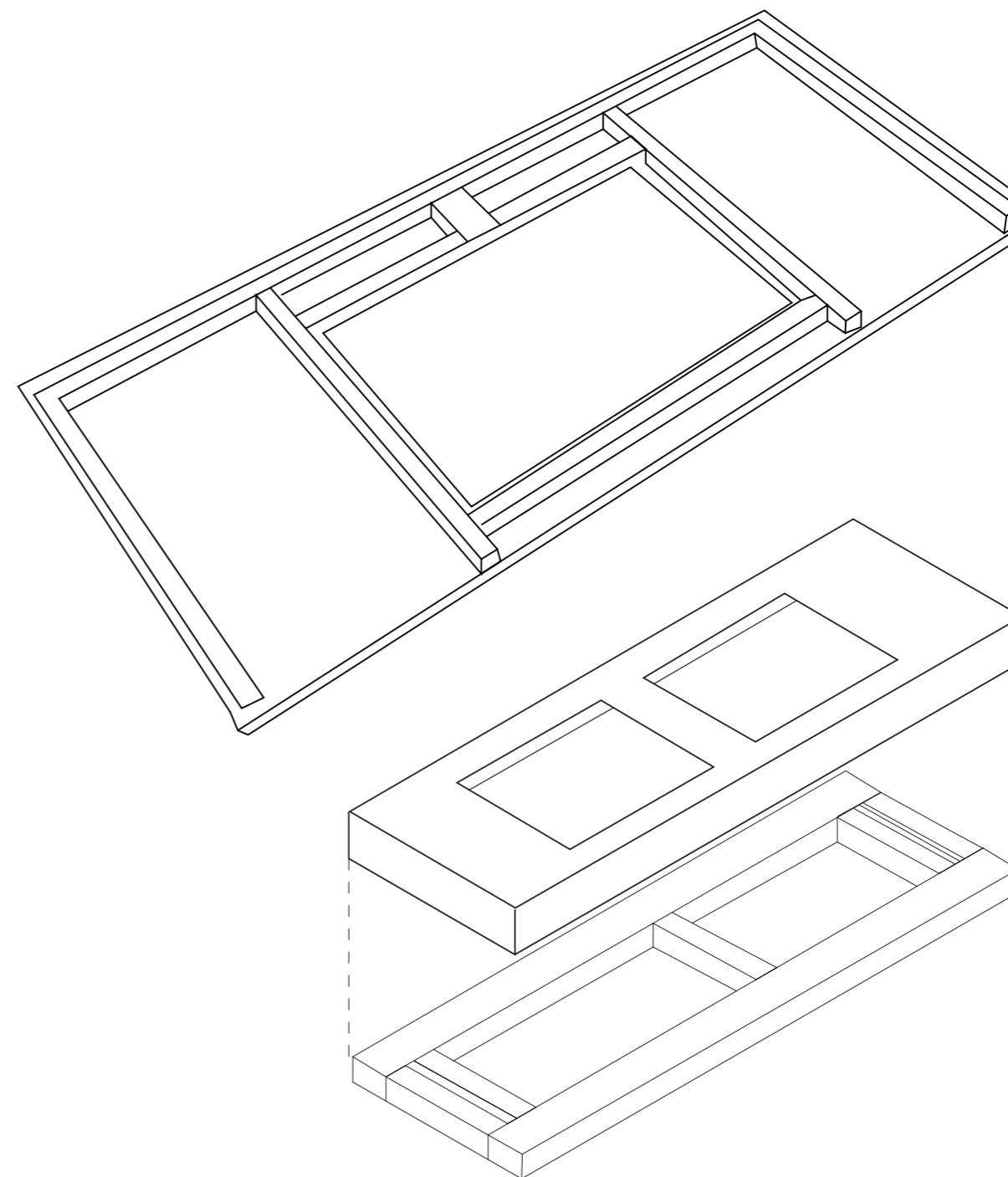



5.9 Overhangs

Ascale slabs in 12 and 20 mm thicknesses allow for overhangs.

Overhangs are not recommended when there are cutouts or holes in the slab at least 15 cm from the edge of the furniture; for holes or cutouts at a distance of 15-60 cm from the edge, the length of the overhangs must be reduced by 50% with respect to the following indications.

Ascale recommends:

SINGLE OVERHANG

Thickness	12 mm	20 mm
	$A \leq 35 \text{ cm}$	$A \leq 45 \text{ cm}$

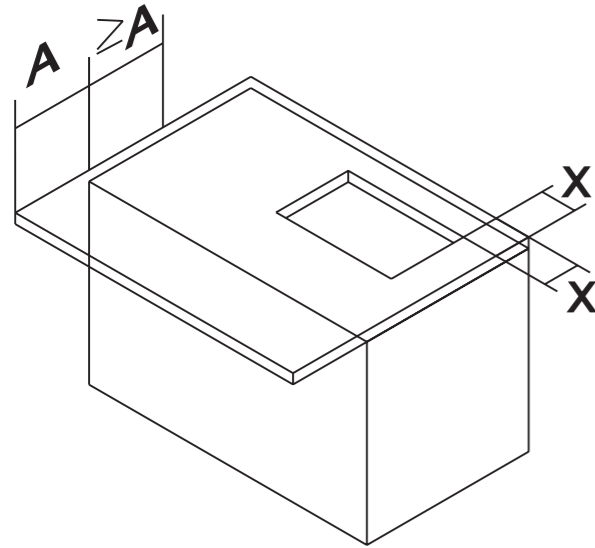
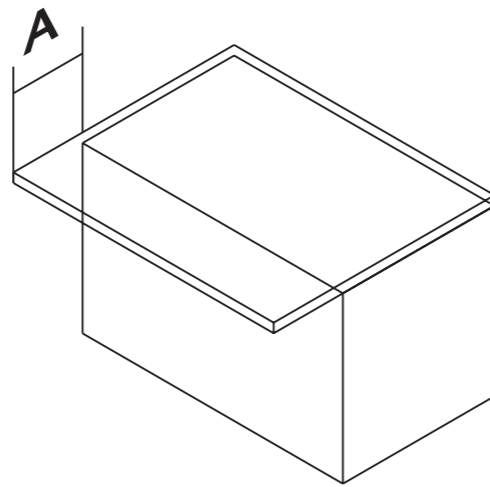

SINGLE OVERHANG WITH A CUTOUT

Thickness	12 mm	20 mm
	$A \leq 35 \text{ cm}$	$A \leq 45 \text{ cm}$
	$X \geq 10 \text{ cm}$	$X \geq 10 \text{ cm}$

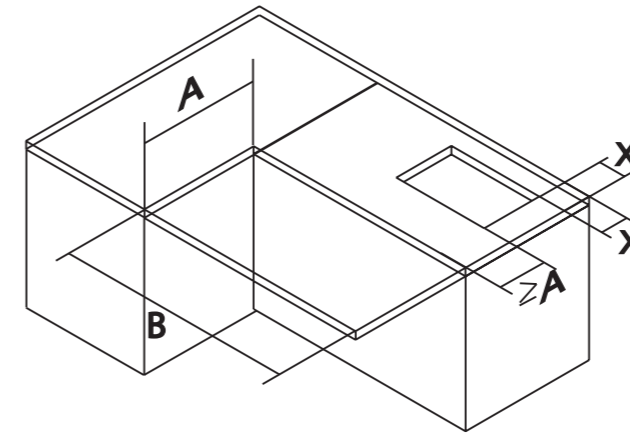

PARTIAL OVERHANG

Thickness	12 mm	20 mm
	$A \leq 15 \text{ mm}$	$A \leq 30 \text{ mm}$
	$B \leq 80 \text{ cm}$	$B \leq 100 \text{ cm}$
	$X \geq 10 \text{ cm}$	$X \geq 10 \text{ cm}$

DOUBLE OVERHANG 1

Thickness	12 mm	20 mm
	$A \leq 25 \text{ cm}$	$A \leq 35 \text{ cm}$

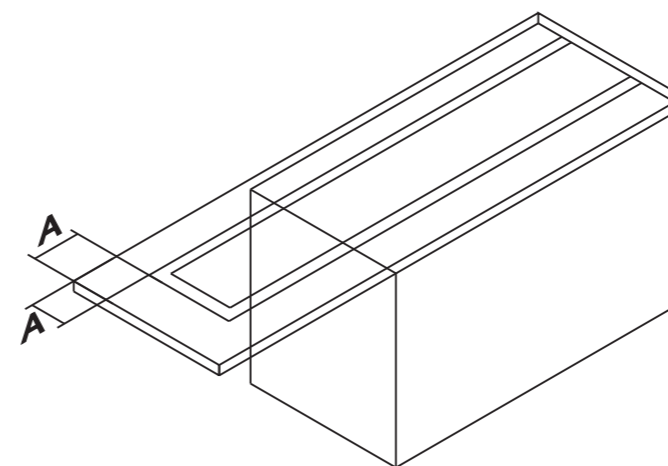
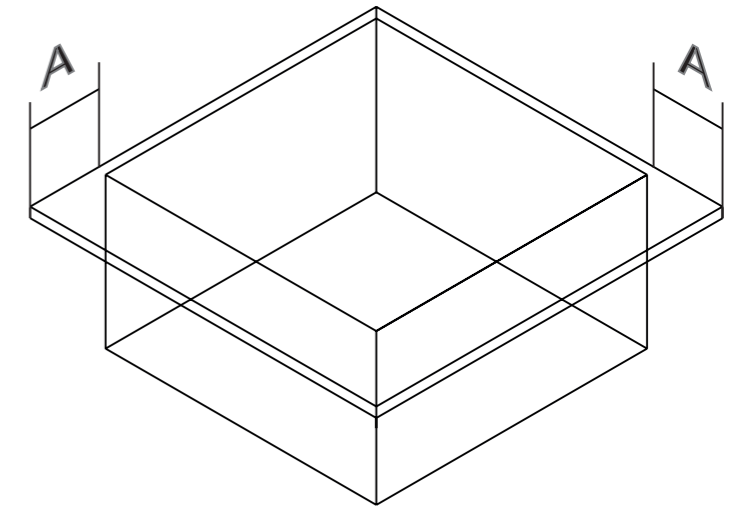

DOUBLE OVERHANG 2

Thickness	12 mm	20 mm
	$A \leq 30 \text{ cm}$	$A \leq 40 \text{ cm}$



6. HEAT

Maximum temperature: 300 °C

Linear thermal expansion: $5.7 \cdot 10^{-6} \text{ } ^\circ\text{C}^{-1}$

Test: Thermal shock resistance (ISO 10545-9); Dry heat resistance (EN 13310)

Ascale slabs can be built in to barbecues and fireplaces for use as Ascale cladding and countertops. The following factors should be taken into consideration:

a) Always consider how each material expands when subject to changes in temperature. Metal materials expand much more than Ascale, so avoid direct contact and leave enough space between them (which will depend on the dimensions, maximum temperature, etc.). Generally speaking, we recommend leaving gaps of 10 mm to prevent breakages caused by this expansion.

b) Whenever possible, create the countertop in several pieces to avoid inside corners. Alternatively, we recommend an inside radius equal to or greater than 10 mm, polishing the edges of the hole to prevent possible microcracks caused by the cutting process.

c) Do not apply the material in direct transmission from the heat source, whether through contact, radiation or ventilation. For example: internal wall tile in the cooking or combustion area, underneath grills, braziers or heating systems.

d) Always protect the material with a refractory wall or insulation to dissipate the heat. We recommend also paying attention to all elements that may heat up, such as the brazier, the ventilation conduit, traditional apparatus, etc.

Examples: Barbecue station. We recommend leaving a space of at least 10 mm from the grill/barbecue and filling it with a thermal insulation material, such as fibreglass thermal insulation tape. We recommend joints on the inside corners.

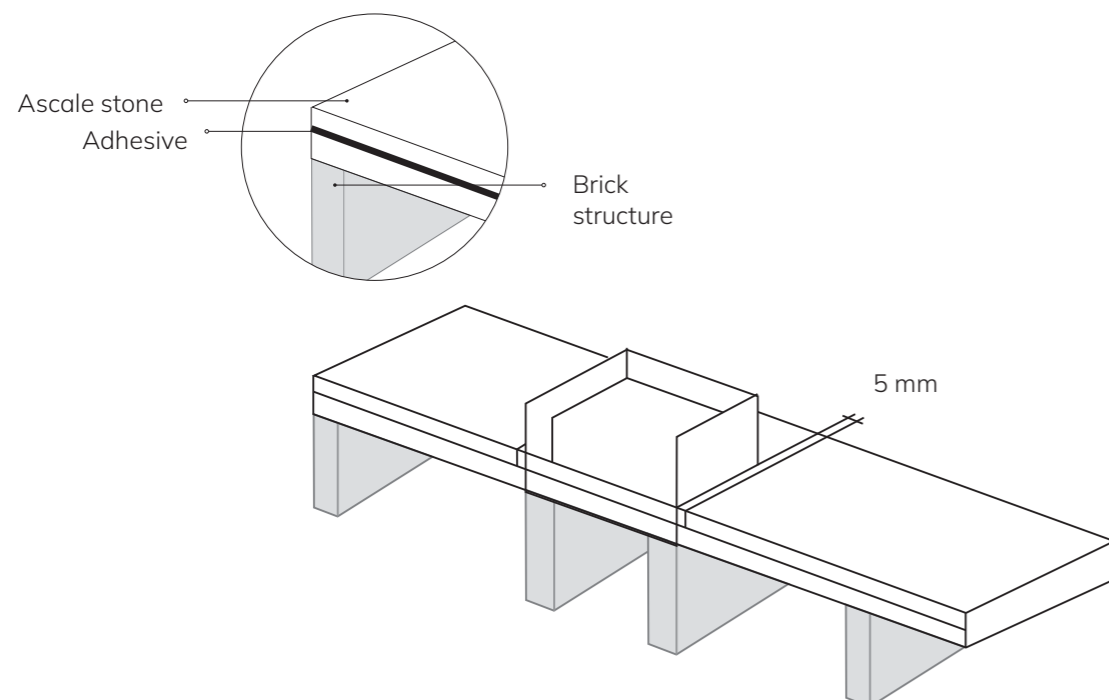

Fireplaces

We recommend leaving a space of at least 5 mm between the fireplace and the Ascale piece, and filling it with a thermal insulation material such as fibreglass thermal insulation tape.

POSIBLES USOS EN CHIMENEAS:

- **Front and side outer cladding:** separated from the heat by a layer of insulation or refractory wall (fire-resistant).
- **Outer side cladding:** separated from the heat by an internal refractory wall.
- **Countertop unit**

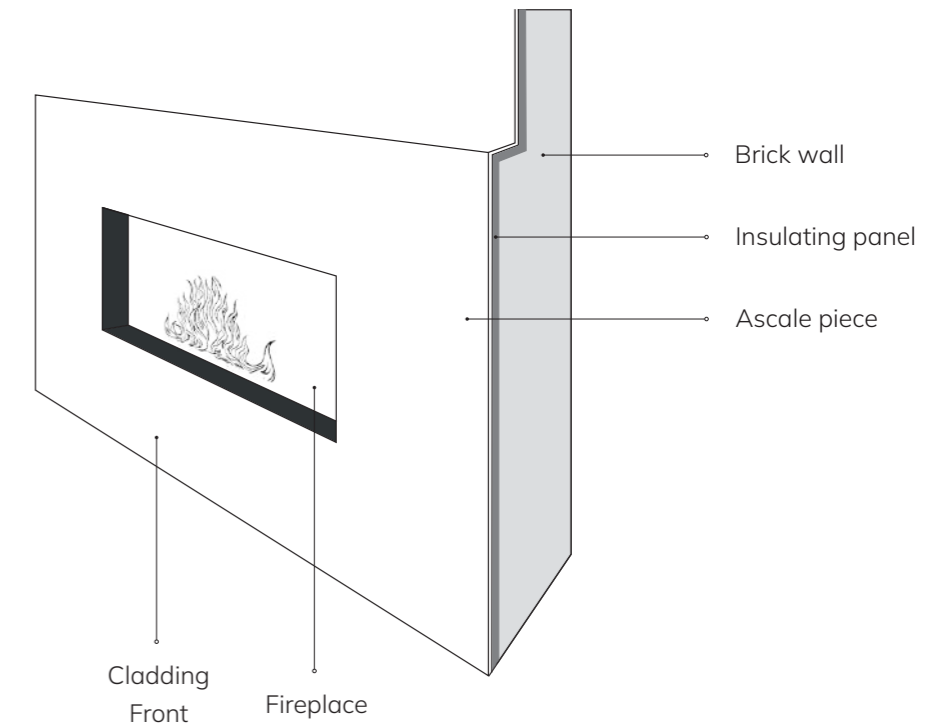

7. ADHESIVES

The 12+ and 20+ Ascale slabs do not usually require reinforcement with other materials.

It may be necessary to glue the slabs, mainly if there is a perimeter panel, to create a filling and a uniform horizontal surface. Adhesives are used when joining Ascale slabs on countertops, the colour of which should be compatible with the body colour of the Ascale material used. Please note that the surface colour of some Ascale models is not exactly equal to the slab body. This is important as the body colour is exposed upon polishing the edges.

The different manufacturers of adhesives for this use recommend their own products that most closely match the colours of Ascale models.

For more information on adequate colours, ask your sales representative or your adhesive supplier. The choice of glued material, the glue to be used and the application frequency are up to the installer and their responsibility. They should be checked according to their suitability for the countertop in question, the materials being used and what they will be used for.



8. CLEANING, MAINTENANCE AND USAGE PRECAUTIONS

For ordinary cleaning, a cloth dampened with water and neutral soap is perfectly adequate.

For more persistent or burned-on stains, we recommend moistening the dirt with hot water (to soften any residues) and then rinsing or removing with a clean cloth. It is also preferable to use a sponge with soft fibres of the type normally used for cleaning glass ceramic and glassware in general.

Particularly abrasive sponges or steel wool must be avoided at all costs.

Ascale recommends against treating the slabs with caustic soda. We also recommend to do not have long application timing both with acid and alkaline products.

If bleach is used, we suggest an application of 10-15 minutes and rinse with plenty of water and never leave the product to remain in contact with the surface of the Ascale surfaces more than the timing specified before.

For the correct maintenance of the slabs, Ascale recommends that you abide by the following precautions:

- Always use pan stands, coasters and napkins
- It is wise not to cut foods directly on the countertop but to use chopping boards for this purpose;
- Never drag household appliances, knives and utensils in general across the countertop, as this may leave steel stains that are difficult to remove;
- Never use ceramic knives directly on the countertop.

HEAT RESISTANCE

Ascale surface complies to the performances required by the EN ISO 10545-1 standard in terms of resistance to thermal shocks.

In particular, Ascale surface tolerates brief exposures to quite hot temperature, however a direct contact with a very hot objects may cause thermal shock and damages.

We therefore do not recommend placing hot items directly from hotplate or out of the oven onto the Ascale surface.

We always recommend the use of a trivet to palace hot items on.

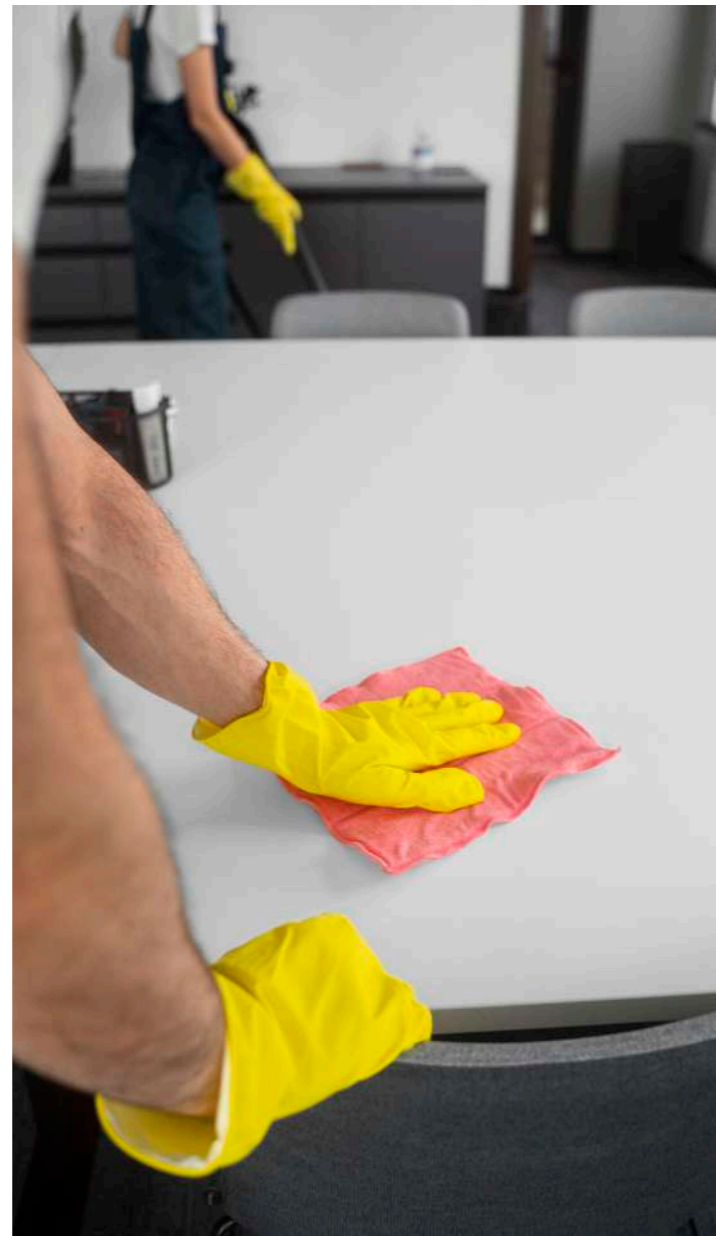

PERSISTENT STAINS

Whenever routine cleaning is insufficient, certain specific procedures need to be followed based on the stain to be removed. The length of time that a stain is left on the surface is important, so we recommend cleaning them as soon as possible. Tip:

Start cleaning a small part of the area in question to verify effectiveness before proceeding to the entire surface. When using more aggressive products, we recommend rinsing with plenty of water once clean. Below is a list of some of the best substances for removing certain stains.

Type of stain	Product (over a Matt-Velvet finish)	Product (over a Polished finish)
Grease	Neutral / Alkaline	Neutral / Alkaline
Oil	Neutral	Neutral
Citric	Neutral	Neutral
Fruit juice	Neutral	Neutral / Alkaline
Soft drinks	Neutral	Neutral
Coffee / tea	Neutral	Neutral / Alkaline
Wine	Neutral	Neutral / Alkaline
Vinegar	Neutral	Neutral / Alkaline
Sauces / Ketchup	Neutral / Cream or powder	Neutral
Ice cream	Neutral	Neutral / Alkaline
Wax candle	Solvent	Solvent
Calcareous residue	Acid	Neutral / Acid
Oxides / rust	Neutral / Acid	Neutral / Acid
Metal scratching	Neutral / Acid	Neutral / Acid
Permanent marker	Cream or powder	Neutral / Alkaline
Resins	Solvent	Solvent



Precautions

- Avoid products that contain hydrofluoric acid and its derivatives. (Oven cleaners, for example).
- Do not use concentrated hydrochloric acid or caustic soda.
- Avoid extreme heat through contact or radiation from electric grills, cooking surfaces, ovens, fireplaces, barbecues, etc.
- Ceramic knives may scratch Ascale surfaces with all finishes, in the same way that they scratch other brands in the same product category and other categories.
- Avoid strong impacts around the edge of a countertop to prevent chipping.

Special consideration for Polished finishes:

1. To clean surfaces with a Polished finish, it should be remembered that this surface resistance is inferior to other finishes, such as Velvet, so some substances may affect its initial appearance. We recommend avoiding the use of scouring pads, knives and other items that may be rough or abrasive for the surface to be cleaned. Cleaners with granules, for example.
2. We also recommend avoiding basic products with a pH above 11. When using bleach, we recommend rinsing with plenty of water and never leaving it in permanent contact. We recommend using flannel or microfibre cloths.

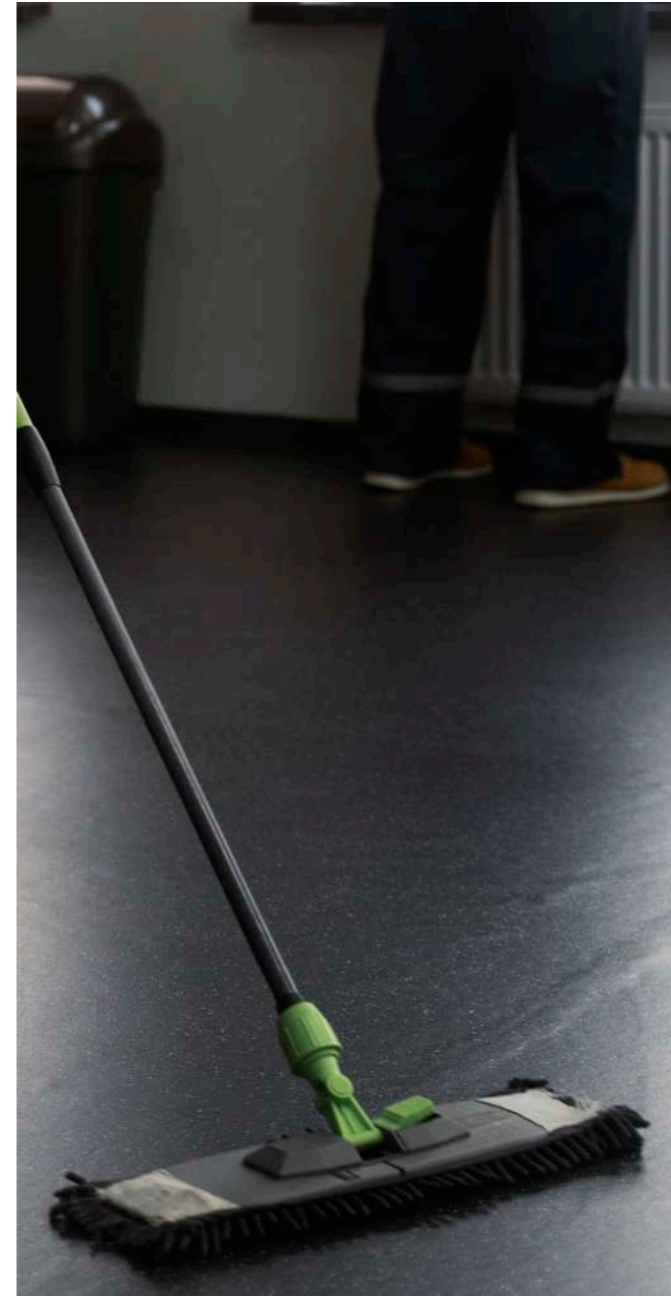

After laying the material it is essential to clean them thoroughly. If residues of grouting are not removed properly or quickly, this may result in stains that are difficult to remove and may create a film of concrete on the floor that traps all kinds of dirt.

To efficiently remove any residues of cement-based grout, it is essential to wash the floor with a solution of water and buffered acid, following the percentages of water/acid indicated on the packaging of the product used.

Allow the detergent to work for a few minutes without letting it dry out, then wipe over the floor with colourless cloths (remove any residues with a stiff brush).

Finally rinse with plenty of water and repeat the operation as necessary.

ORDINARY FLOOR CLEANING

Ascale recommends against the use of oily soaps and waxes, and recommends instead neutral detergents, such as ammonia or bleach, that have been suitably diluted in water.

After washing, the floor should only be dried if it has a polished finish (to avoid any visible stains from appearing).

We always recommend testing any detergent before use, always following the instructions and the precautions indicated by the manufacturer.





EXTRAORDINARY FLOOR CLEANING

In the case of residues and stains that are particularly stubborn and difficult to remove, Ascale suggests cleaning the surface first with warm water and neutral detergents.

For persistent stains, then use more intense cleaning methods using specific products (depending on the type of stain to be treated):

- Non-abrasive detergents with a neutral pH
- Slightly abrasive detergents
- Acid or alkaline detergents
- Solvent-based detergents

We recommend always following the instructions and precautions indicated by the manufacturer.



Scan
the QR code



Ctra. Castellón, 117, 12110 L'Alcora, Castellón +34 964 77 77 00

www.ascale.es/en

